

BUILDING
COMMON GROUND



Spacers

Distance tubes

Sealing cones & plugs

Steel spacers



BUILDING
COMMON GROUND



Spacers

Distance tubes, Sealing cones & plugs,
Steel spacers

Contents

Applications	4
Product overview	5
Spacers	6
Standards and dimensioning	8
Block spacers	10
Bar spacers	14
Special spacers	19
Fibre-reinforced concrete distance tubes	22
Sealing caps and cones	25
Sealing options	26
Fibre-reinforced concrete sealing plugs	27
Properties with regard to building physics	28
Steel spacers – U-Korb® wire spacer	30

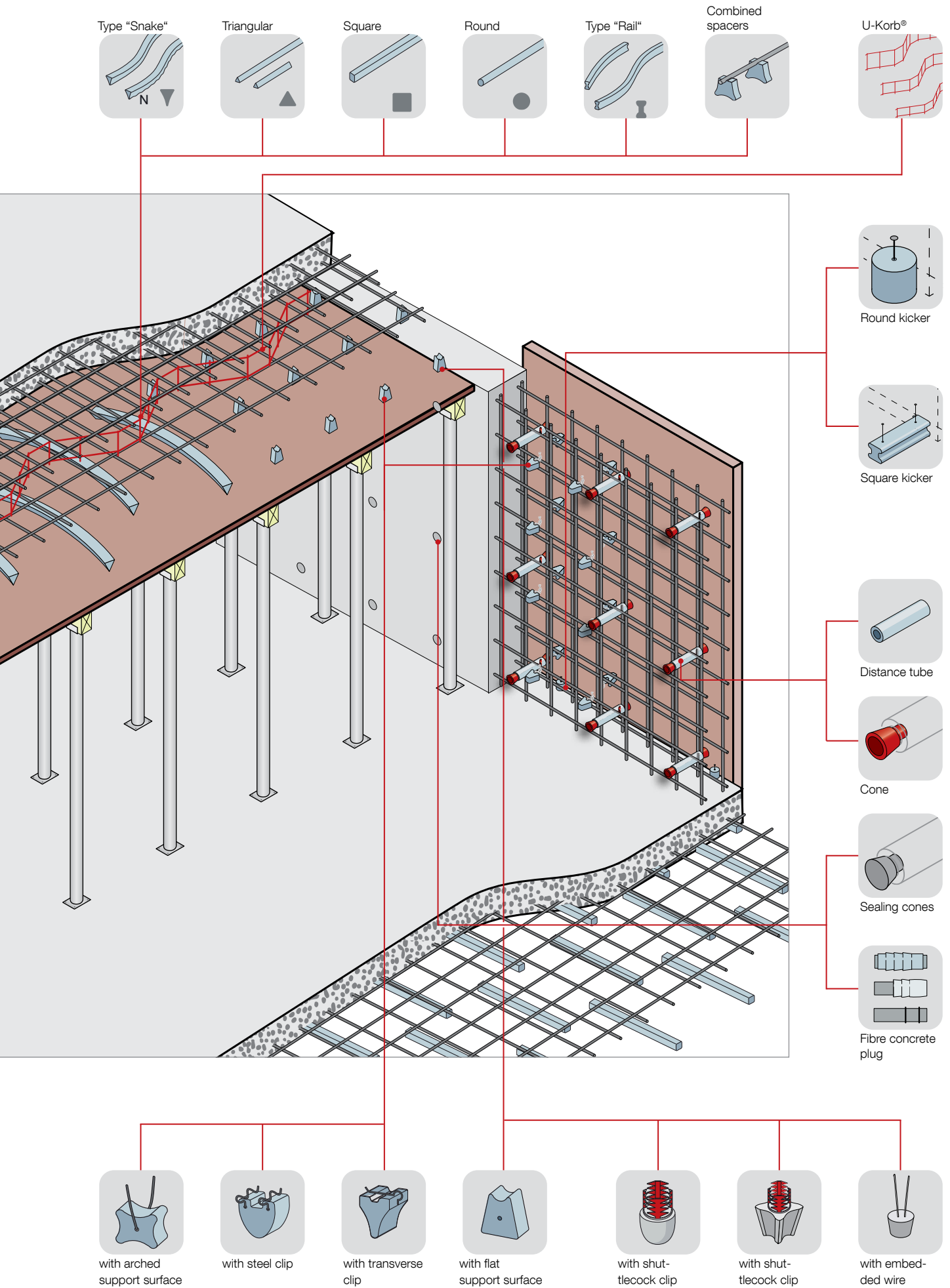

Block spacers

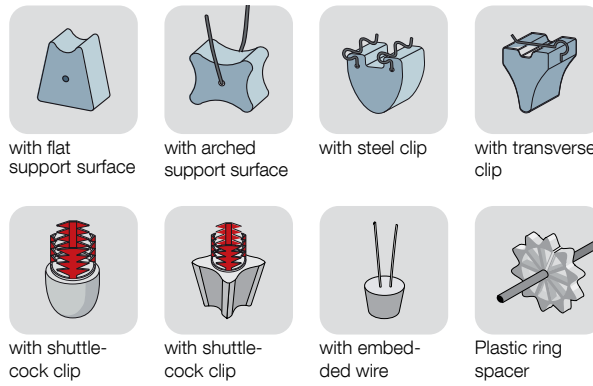

with flat support surface

with arched support surface

with steel clip

with transverse clip

with shuttle-cock clip

with shuttle-cock clip

with embedded wire

Plastic ring spacer

Bar spacers

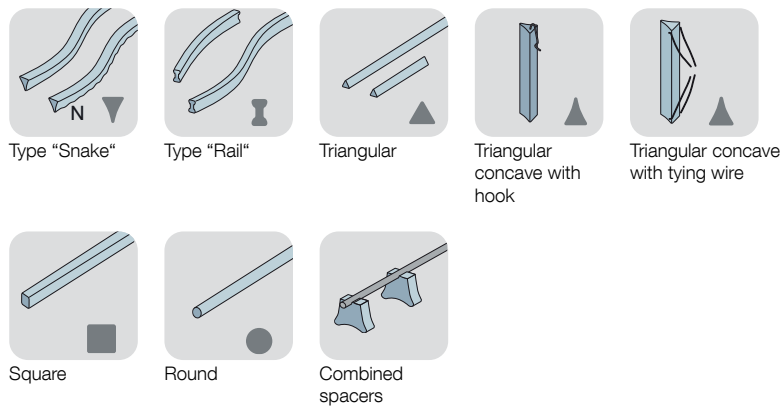

Type "Snake"

Type "Rail"

Triangular

Triangular concave with hook

Triangular concave with tying wire

Square

Round

Combined spacers

Formwork kickers

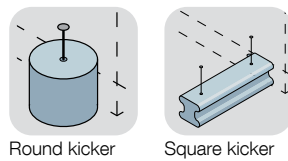

Round kicker

Square kicker

Special spacers

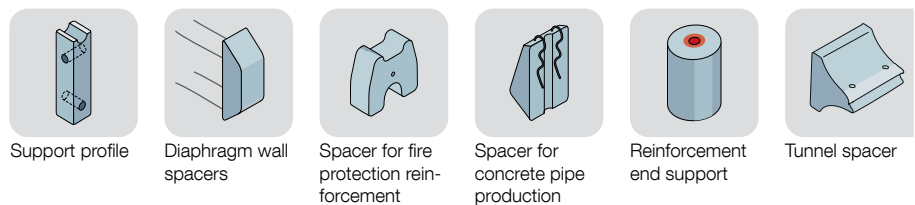

Support profile

Diaphragm wall spacers

Spacer for fire protection reinforcement

Spacer for concrete pipe production

Reinforcement end support

Tunnel spacer

Distance tubes

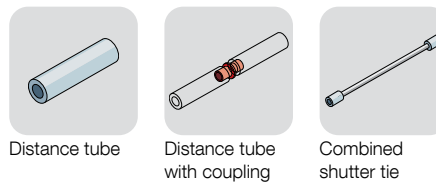

Distance tube

Distance tube with coupling

Combined shutter tie

Plugs / Sealing cones

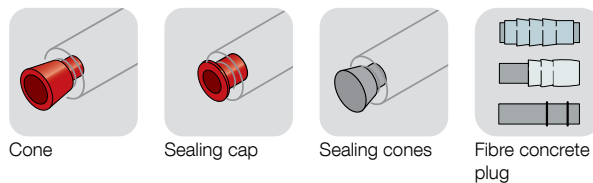

Cone

Sealing cap

Sealing cones

Fibre concrete plug

Steel spacers – U-Korb® wire spacer



U-Korb® wire spacer



Fibre-reinforced concrete spacers

Spacers made of extruded fibre-reinforced concrete are dimensionally accurate and have a constant high quality and outstanding chemical and physical resistance. The good bond with the structural concrete prevents the formation of hairline cracks. Spacers made of fibre-reinforced concrete fulfil the requirements of all exposure classes. All concrete mixes used have been tested by independent testing institutes with regard to the required properties.

- Tested according to DBV-Merkblatt "Spacer - version from January 2011" of the German Concrete Association
- KOMO certificate– our fibre concrete spacers are certified according to the Dutch assessment directive BRL2817

Block Spacers

- High compressive strength, no deformation in heat or cold, concrete cover accurately maintained.
- Spacers remain in position during formwork erection and concreting
- Ideal for impermeable concrete, no hairline cracks between the spacer and the concrete

Bar Spacers

- High compressive strength, no deformation in heat or cold, concrete cover accurately maintained.
- Ideal for impermeable concrete, no hairline cracks between the spacer and the concrete
- Large support area- reduced pressure on the formwork
- Substantial labour cost savings due to rapid and simple laying
- Fire resistant to the highest requirements specified in EN13501-1:2002 - Class A1 (non combustible)
- All bar spacers over 330 mm long have increased resistance to breakage due to a reinforcing thread.

The following points must be considered when selecting spacers:

- Notes for the selection of the spacer in relation to the exposure class according to EN 1992-1-1:2011-01 (Eurocode 2)
- The selection of spacer types and properties depends upon the structural element and application, always refer to local concrete standards for advice.
- Required concrete cover according to EN 1992-1-1:2011-01, section 4.4.1 Nominal dimension of the concrete cover c_{nom}
- Load on the spacer due to the weight of the reinforcement and additional loads, e.g. during concreting and when installing the reinforcement or other built-in parts.
- Diameter and location of the reinforcement – wall/ceiling
- Type of reinforcement – single bar or mats
- Simple, fast and economical installation
- Type of fastening – without wire, with wire, with steel or plastic clips
- Influences acting on the concrete from outside, e.g. pressure, temperature, chemical attacks, moisture variations, fire and corrosion
- Treatment of the concrete surface (stucco work)
- Exposed concrete – imprint of the spacers in the concrete surface (see DBV data sheet "Exposed concrete")

Required quantities and positioning

Thin rebar can bend during concreting.

If the reinforcement is very heavy, check the spacer loading capacity!

The fixing interval is based primarily on the accepted deflection at maximum loading, e.g. when the reinforcement is walked on, especially during concreting. When placing bar spacers in the tension zone of the component to be concreted, use spacers of reduced length and arrange them with overlaps.

Recommendations for spacing and number of spacers

Structural element: slabs

Spacer fixing distance S

Supported bars \varnothing	max. S	Pcs. required per m^2			
		Block spacers	Bar spacers $L = 18\text{ cm}$	Bar spacers $L = 33\text{ cm}$	Bar spacers $L = 100\text{ cm}$
up to 6.5 mm	0.50 m	4	3.0	2.5	1.33
from 6.5 mm	0.70 m	2	1.6	1.4	0.84

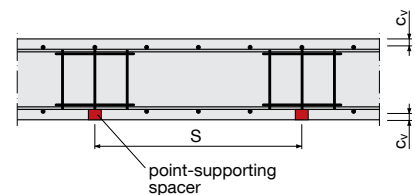

Structural component: beams and columns

Spacer fixing distances max. S_1 in longitudinal direction

longitudinal bars \varnothing	columns	beams
up to 10 mm	0.50 m	0.25 m
12 to 20 mm	1.00 m	0.50 m
over 20 mm	1.25 m	0.75 m

Spacer fixing distances max. S_2 in transverse direction

Quantity, distances		
b or h	columns	beams
bis 1.00 m	2 Stück	2 Stück
über 1.00 m	≥ 3 Stück	≥ 3 Stück
max. S_2	0.75 m	0.50 m

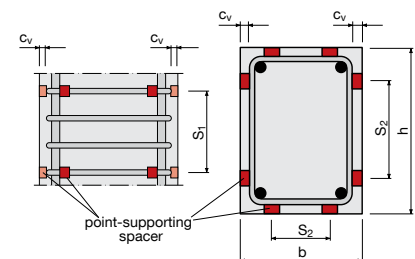

Structural element: walls

Spacer fixing distances S_1 and quantity

supporting bars \varnothing	max. S_1	Pcs. required per m^2 wall*	
		Block spacers	Bar spacers $L = 33\text{ cm}$
bis 8 mm	0.70 m	4	1.4
über 10 mm	1.00 m	2	0.8

*and per wall side

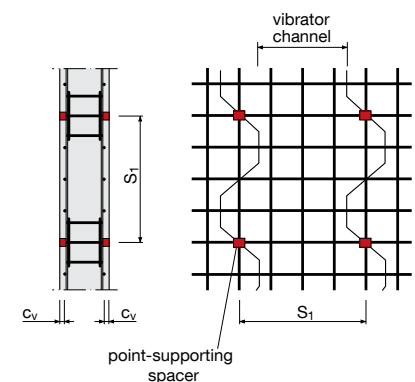

Note: Above recommendations are in accordance with the DBV data sheet for spacers issued by the German Concrete Association. Refer to local standards where applicable.

Spacer Standards

Reinforced concrete durability is only achieved by protecting the steel reinforcement from environmental attack.

The level of that protection depends not only upon the quality of the cover concrete but also upon the type and quality of the spacers that are used. The focus of standards/specifications on improving concrete quality and durability has not been matched by improved spacer requirements.

Eurocode 2 and the BS, DIN and AS/NZS standards have clearly specified spacer strengths and dimensional tolerances and their adoption improves concrete performance. Reflecting the recognition of how spacers can affect concrete durability, standards/specifications are now also including spacer durability properties that require them to match or exceed those of the host concrete.

Specification	BS7973	AS/NZS2425	EN206/ DIN1045
	UK spacer standard	Australia & New Zealand spacer standard	European & German standard



Compressive Strength			
	50 MPa	60 MPa	50 N/mm ²

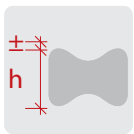

Dimensional Tolerances			
heights ≤ 75 mm	±1 mm	-1 mm to +2 mm	≤40 mm ±1 mm
heights > 75 mm	±2 mm	±2 mm	>40 mm ±2 mm



Point Load			
Heavy (H)	3.00 kN	300kg	2.0kN



Deflection under load			
	n/a	±3 mm	2 mm

Permanent deflection			
	≤ 1.00 mm	< 2.00 mm	n/a

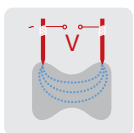

RCP Test			
(ASTM C1202)	n/a	< 1,000 Coulomb*/***	n/a

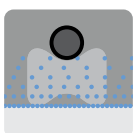

Chloride Diffusion			
(Nordtest NT Build 443)	n/a	Type Testing**	n/a

* higher coulomb values are acceptable for some applications

** NT Build Test to be used as a calibration for the RCP Test

*** Non-stock item, delivery time on request

Additional characteristics

Due to environmental factors and application requirements, spacers may need to meet quality requirements that exceed current spacer standards. To ensure that you always have the correct spacer, we can create special spacers to meet your requirements. These spacers are usually not stock items.



Drinking Water Applications

In many countries any products that come in contact with potable/drinking water require independent certification of their suitability for use. Essentially materials in contact with the water must not deteriorate the microbiological condition of the water. MAX FRANK produce a range of approved spacers for such applications.



Fire Resistance

Fire resistance of structures and all structural elements is considered of primary importance. Although small in size any burn-out of a spacer during a fire event is to be avoided. All MAX FRANK extruded fibre reinforced concrete and cast concrete spacers are fire resistant to the highest requirements specified in EN13501-1:2002 – Class A1.



Water Absorption

In most applications the water absorption of the concrete has a significant impact on the life and performance of the structure, particularly for those in contact with water. Spacers in such structures also need to be resistant to water absorption. MAX FRANK can produce spacers with varying resistance to water absorption to meet your project needs.



Chloride Resistance

Chloride attack is very prevalent in marine environments and also in the presence of de-icing salts. Reinforcement not protected by spacers of a suitable quality will cause premature structural failure. MAX FRANK produces spacers with chloride ingress values to match or surpass those of the host concrete, thus ensuring maximum structural durability.



Sulfate Resistance

Structures exposed to chemical attack from sulfates, require special highly sulfate resisting spacers. In accordance with EN206-1 these spacers may be used for Exposure Classes XA2 and XA3. MAX FRANK produces spacers made from special mixes that fulfil the requirements of these exposure classes.



Fair-faced concrete applications

Fair faced concrete to the specified standard can be hard to achieve and can be negatively influenced by the use of the wrong spacer and sealing cones. The range of spacers includes different shapes and colours to help minimize visibility of the spacer on the finished surface. Sealing cones for sealing tie-bar holes are also available in different colours and finishes to help ensure that you get quality exposed concrete to the highest standards.

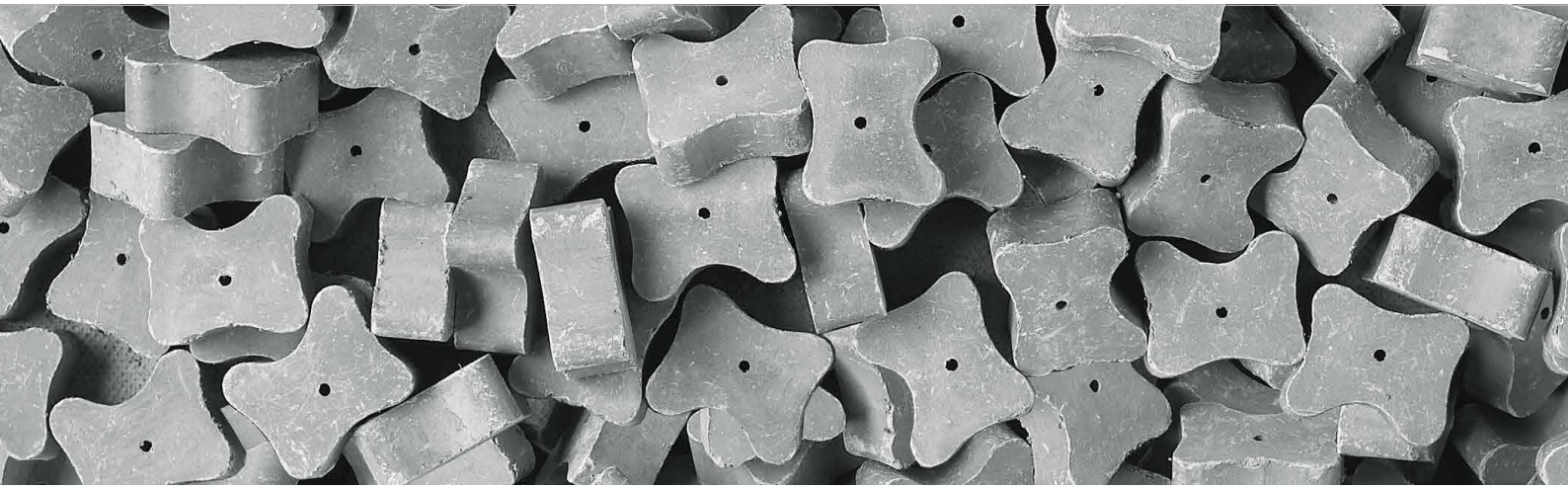

Block spacers

Spacers are used to ensure that the specified cover to the reinforcement in concrete structures and structural elements is maintained both before and during concreting.

We offer you the ideal spacer for every application:

	with flat support surface	with arched support surface	with steel clip	with transverse clip	with shuttlecock clip	with embedded wire
Type series	AO / AD	AO / AD	AK	AK-Q	AB	AB
Drawing						
horizontal reinforcement	+	+ ¹⁾	-	-	+	+
vertical reinforcement	+	+ ¹⁾	+ ¹⁾	+ ¹⁾	+ ¹⁾	+
Exposed concrete ²⁾	-	+	+	+	+	-
type group ³⁾	B1 / B2	B1 / B2	B2	B2	B2	B2

- ⊕ suitable
- conditionally suitable
- ⊖ not suitable

¹⁾ if tilting or displacement is not possible

²⁾ Check suitability of spacer on a test surface before use with exposed concrete or self-compacting concrete (SSV).

³⁾ Type group according to DBV data sheet "Spacers"

B1 = point-supporting, not fixed

C1 = linear-supporting, not fixed

B2 = point-supporting, fixed

C2 = linear-supporting, not fixed

Spacers with flat support surface

For horizontal and vertical structural elements

- Available without wire/with black wire/with galvanized wire/with stainless steel wire
- Suitable for high load distribution
- Available covers from 15 mm to 100 mm
- Available in various cut widths



Spacers with arched support surface

For horizontal and vertical structural elements

- Available without wire/with black wire/with galvanized wire/with stainless steel wire
- Suitable for fair faced and aesthetic concrete

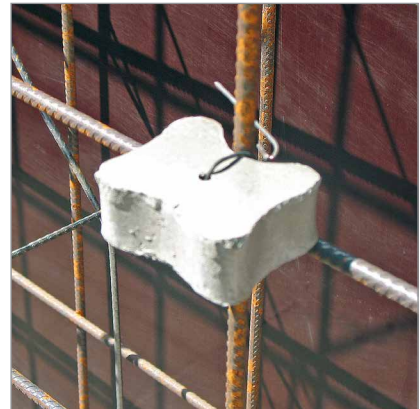

Spacers with steel clips

For vertical structural elements

Spacers with two steel clips and a groove to seat the reinforcement. The size of clip and groove can be varied to suit your reinforcement. Very high stability is achieved by fixing the spacer at the crossing point of reinforcement layers.

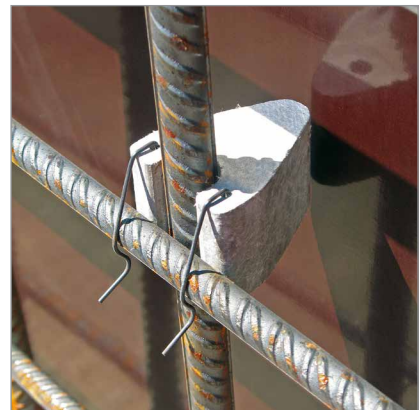

Spacers with a transverse clip

For vertical structural elements

Spacers with a single transverse steel clip and a groove to seat the reinforcement. The size of clip and groove can be varied to suit your reinforcement.

- No steel within the cover zone
- Covers from 30 mm to 50 mm

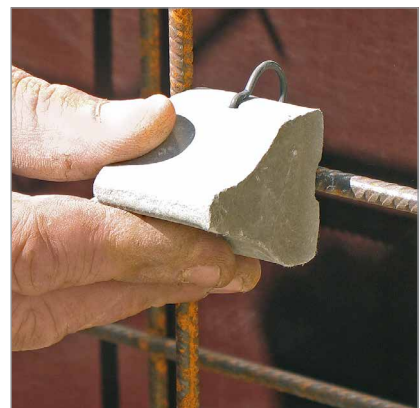



RONDO spacers

Simplify the fitting of formwork

- Used for inserting prefabricated cages into formwork
- Helps prevent damage to spirally wound cardboard column formers



Spacers made of cast concrete with shuttlecock clip

For vertical and horizontal structural elements

Spacers with shuttlecock clips enable simple and fast fixing to the reinforcement. Suitable for use with reinforcements that are not walked on, e.g. in the precast plant.

- Available in covers from 20 mm to 60 mm
- Minimal surface contact

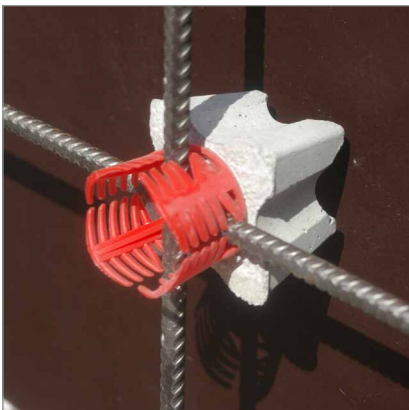

Spacers made of cast concrete with shuttlecock clip

For vertical and horizontal structural elements

Spacers with shuttlecock clips and four-point support enable simple and quick fixing to the reinforcement. Suitable for use with reinforcements that are not walked on, e.g. in the precast plant.

- Available in covers from 20 mm to 60 mm
- Spreads load whilst minimizing surface contact

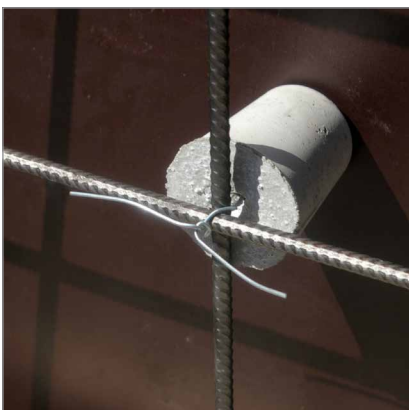

Spacers made of cast concrete with embedded wire

For vertical and horizontal reinforcement

Large contact surface and stable fixing for use on the building site and in the precast plant.

- Available in covers from 20 mm to 100 mm
- Available with galvanised (stock) or stainless (non-stock) steel tying wire
- Also available in other profiles



Plastic ring spacers

For vertical structural elements

Fast and simple fixing to the reinforcement with max. diameter 10 mm.

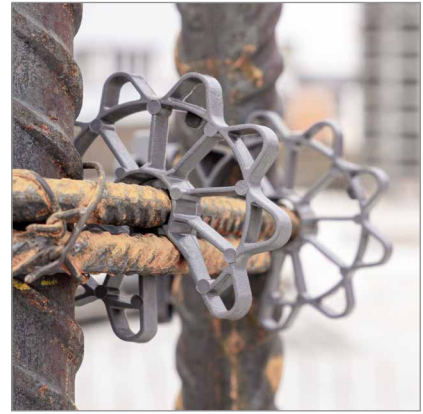

Formwork kicker made of fibre-reinforced concrete

Serves as a stop spacer between formwork and reinforcement for fixing the formwork in the right place on the inside.

Versions: without nail insert / with nail insert



Formwork kicker made of fibre-reinforced concrete

Serves to ensure the wall thickness and is nailed to the floor slab.

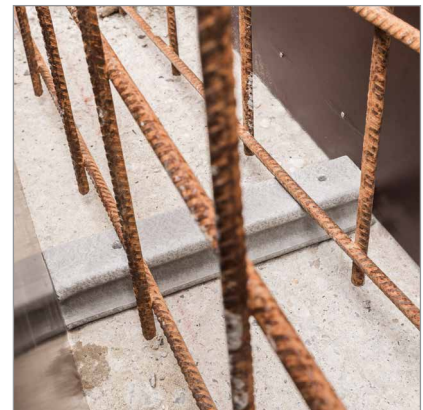



Bar spacers

Bar spacers are used to ensure that the specified cover for concrete structures and structural elements is maintained, both before and during concreting. Bar spacers are supplied in cover depths from 20 mm to 100 mm and lengths of 180 mm, 250 mm, 330 mm, 800 mm and 1,000 mm depending upon spacer type and application.

We offer the ideal spacer for every application:

	Snake, Snake N ⁴⁾ + Banana N ⁴⁾	Rail + Rail B	Triangular	Triangular concave	Triangular concave with hook	Triangular concave with tying wire	Square	Round	Combined spacers
Type series	FAHKS FAHKBN	FAHSS FAHSB	FAHD	FAHK	FAHDH	FAHKZD	FAHV	FAHR	KOMBI KOMBST
Drawing									
horizontal reinforcement	⊕ ¹⁾	⊕ ¹⁾	⊕ ¹⁾	⊕ ¹⁾	⊖	○	⊕ ¹⁾	⊕ ¹⁾	⊕
vertical reinforcement	⊖	⊖	⊖	⊖	⊕	⊕ ¹⁾	⊖	⊖	⊖
Exposed concrete ²⁾	○	⊖	⊖	⊖	○	○	⊖	○	⊕
type group ³⁾	C1	C1	C1	C1	C2	C2	C1	C1	B1/C1

- ⊕ suitable
- conditionally suitable
- ⊖ not suitable

¹⁾ When installed transversely to the tension direction of the main reinforcement spacer length should be limited to: 350 mm or $\leq 2 \times h$ or $\leq 0,25 \times b$, whereby h = structural element thickness and b = structural element width.

When installed longitudinally to the tension direction of the main reinforcement:

- spacer length is not limited
- concrete spacers to be used

²⁾ Check suitability of spacer on a test surface before use with exposed concrete or self-compacting concrete (SSV).

³⁾ Type group according to DBV data sheet "Spacers"

B1 = point-supporting, not fixed

B2 = point-supporting, fixed

C1 = linear-supporting, not fixed

C2 = linear-supporting, fixed

⁴⁾ "N" notched

Bar spacer type "Snake"

For horizontal applications

Use with mesh and loose bar reinforcement

- Suitable for the fast and economic installation of mats and single bar reinforcements
- Stable, non-tipping – simple to install

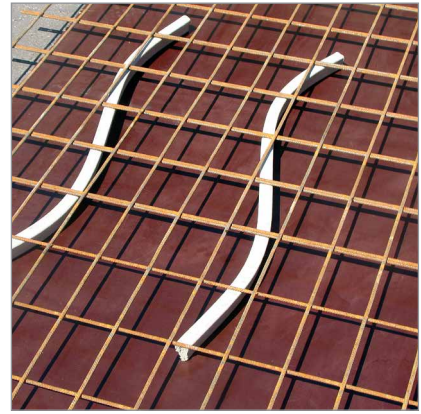

Bar spacer type "Snake N"

With notches for horizontal applications

Use with mesh and loose bar reinforcement

- Suitable for the fast and economic installation of mats and single bar reinforcements
- Stable, non-tipping – simple to install
- Designed for use with exposed / architectural concrete due to reduced interface with formwork

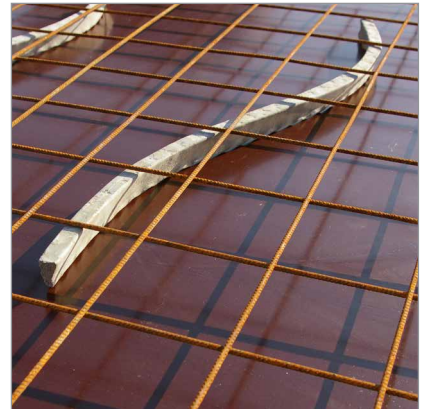

Bar spacer type "Banana N"

With notches for horizontal applications

Use with mesh reinforcement

- Manufacturing length 33 cm specially for R-mats and manufacturing length 25 cm specially for Q-mats
- Stable, non-tipping – simple to install
- Designed for use with exposed / architectural concrete due to reduced interface with formwork

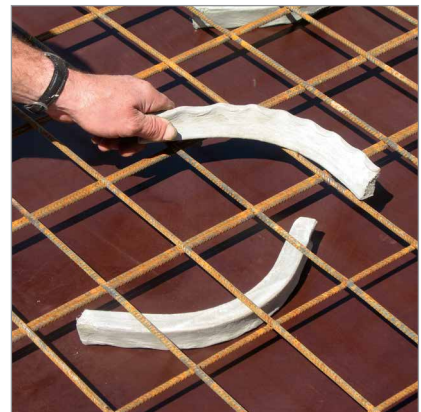

Bar spacer type "Rail"

For horizontal applications

Use with mesh and loose bar reinforcement

- Suitable for the fast and economic installation of mats and single bar reinforcements
- Stable, non-tipping – simple to install
- High load-bearing capacity

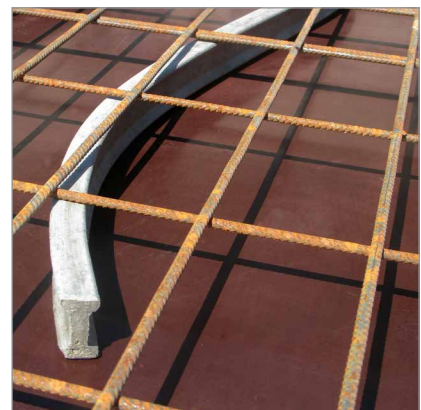



Bar spacer type "Rail B"

For horizontal applications
Use with mesh reinforcement

- Suitable for the fast and economic installation of mats and single bar reinforcements
- Stable, non-tipping – simple to install
- High load-bearing capacity



Triangular bar spacers

For horizontal applications
Use with mesh and loose bar reinforcement

- Application safety – triangular bar spacers always have the same concrete cover in every position
- Large support surface reduces compressive loads with insulated floor slabs

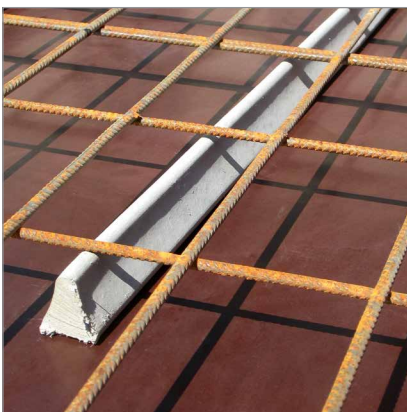

Triangular concave bar spacers

For horizontal applications
Use with mesh and loose bar reinforcement

- Suitable for the fast and economic installation of mats and single bar reinforcements
- Triangular concave bar spacers do not have the same concrete cover in every installation position. Triangular bar spacers should be used if there is a danger of tipping over.

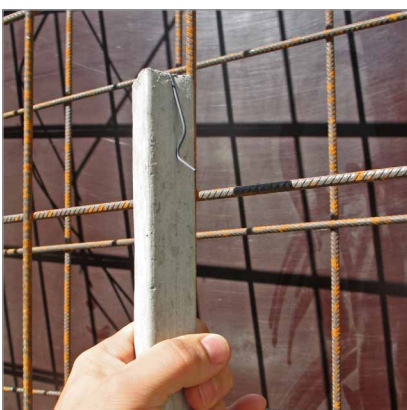

Triangular concave bar spacers with hook clip

For vertical applications
Use with mesh and loose bar reinforcement

- Fixed to vertical reinforcement by simply hooking on
- The length must be selected according to the reinforcement spacing



Triangular concave bar spacers with two wires, equilateral shape

For vertical and curved applications

For safe fixing in every installation position

- Safe fixing in every position, including overhanging reinforcement
- Non-tipping thanks to large support width
- The length must be selected according to the reinforcement spacing



Square bar spacers

For horizontal applications

Use with mesh and loose bar reinforcement

- Very high load-bearing capacity, also suitable for particularly heavy reinforcement and non-tipping due to large support area.
- Large support surface reduces compressive loads with insulated floor slabs

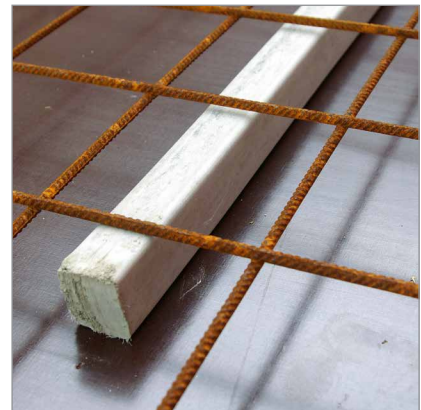

Round bar spacers

For horizontal applications

Use with mesh and loose bar reinforcement

- Used in both precast and in-situ applications
- High load bearing capacity
- Generally suitable for exposed concrete due to almost invisible linear contact

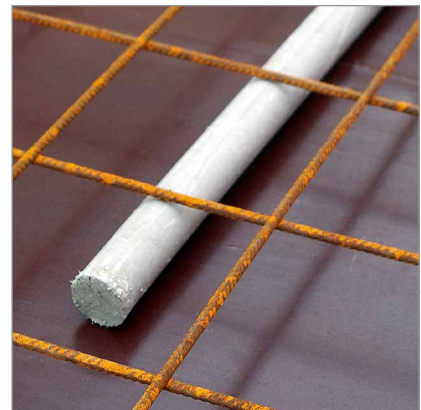



Combined spacers

For horizontal applications

- Consists of a reinforcing bar and spacers made of fibre-reinforced concrete
- Designed for a low load and therefore suitable for reinforcement that is not walked on
- Used mainly in precast applications
- Suitable for exposed concrete

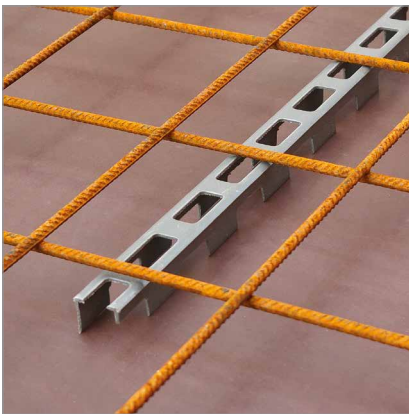

U-Pro "with"

For horizontal applications

With lateral cut-outs

- Made of plastic
- Designed for low loads

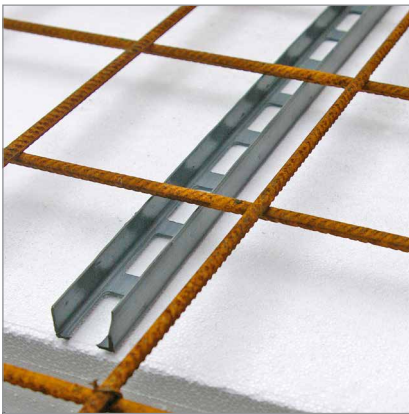

U-Pro "without"

For horizontal applications

- Pressing into the insulation is prevented by the wide support surface.
- Designed for low loads



Special spacers

Special spacers are manufactured quickly and efficiently to meet your demands. We offer you numerous technically accurate and inexpensive possibilities from supporting profiles for internal formwork in bridge building up to filigreed spacers.

Spacers according to your technical requirements

- We manufacture custom sizes and custom shapes according to your specifications – quickly and economically
- Production in fibre-reinforced concrete is possible even in small batches with low tool costs
- Mixtures with
 - special cements (HS, white cement)
 - colour pigments
 - increased strength
 - see page 9 for further properties

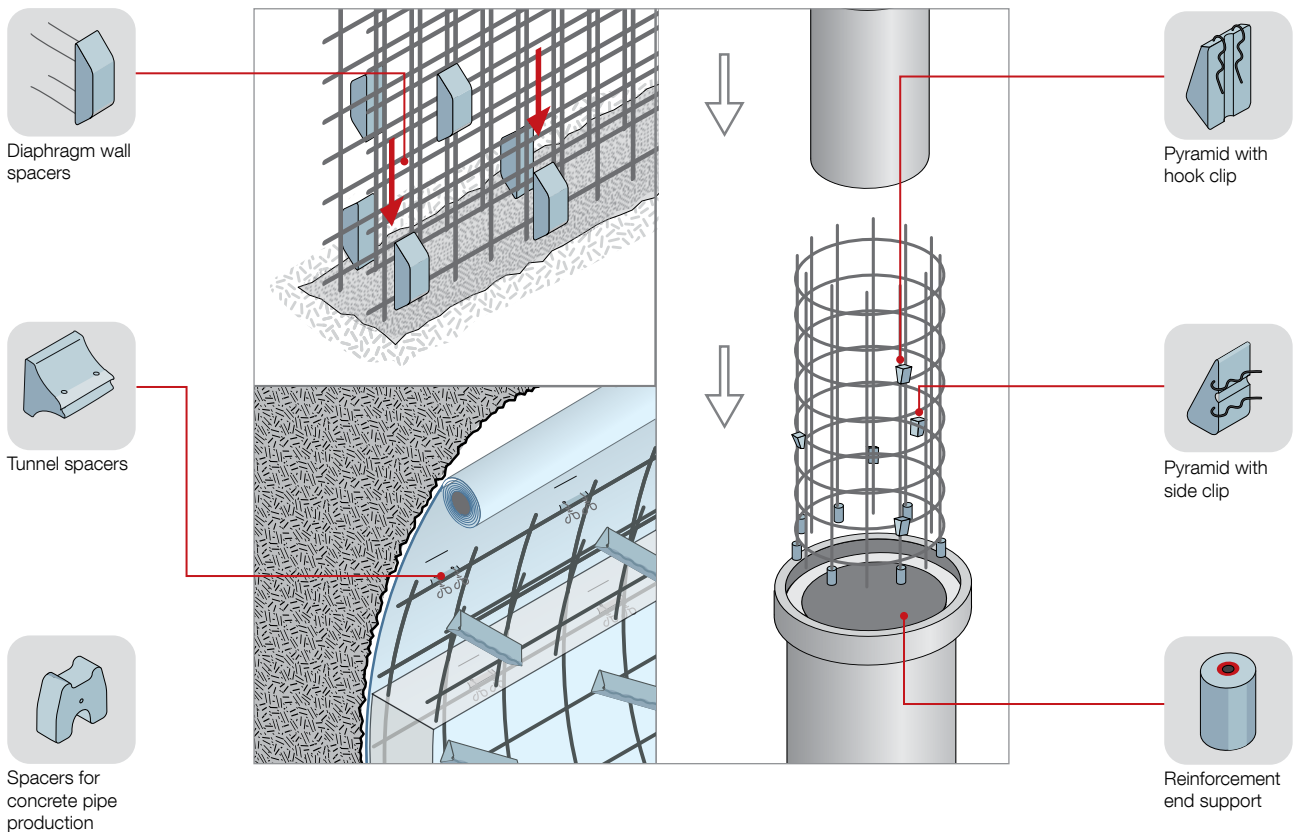

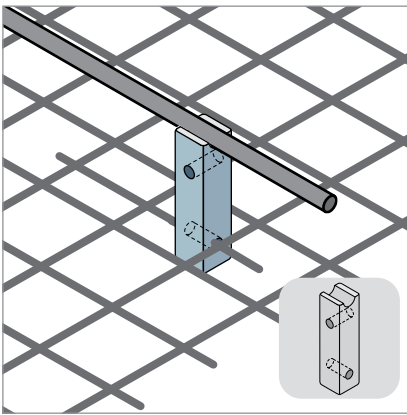

Support profile

Block spacers that can be used as supports for internal formwork, reinforcement sleeves for prestressing elements and to support upper and lower reinforcement layers.

These spacers are made exactly to meet the needs of each individual project including dimensional and durability requirements.

These spacers can be produced with a square or rectangular cross-section to different dimensions. Grooves and various cross holes for the support of reinforcement are matched to the site reinforcement..

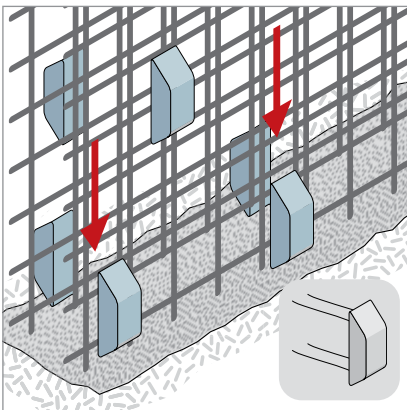

Diaphragm wall spacers

Diaphragm wall spacers are used for lowering prefabricated reinforcement cages into cast-in-situ concrete diaphragm walls. Thanks to the large support surface and the tapered lateral surfaces of the diaphragm wall spacer, the reinforcement cages slide centrally into the prepared slot.

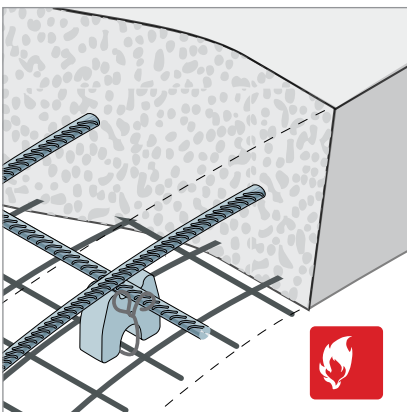

Spacers for fire protection reinforcement

Guideline from the German Highway Research Institute (BAST) for road tunnels, the ZTV-ING Part 5, Section 1 and 2 provide for the arrangement of an additional fire protection reinforcement. This fire protection reinforcement is intended to prevent excessive heating of the load-bearing reinforcement beyond the critical temperature of 300 degree Celsius. This added protection helps to prevent the spalling of large areas of concrete during a fire event.

The purpose of these spacers is to maintain the concrete cover of both the fire protection reinforcement and the load-bearing reinforcement. To do this the fire protection reinforcement is laid on the formwork, the spacers are placed above it, the load-bearing reinforcement is laid and finally the fire protection reinforcement is pulled up by tying.

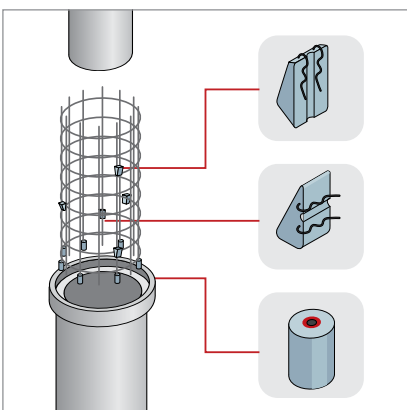

Spacers for concrete pipe production

MAX FRANK spacers with clips help to maintain concrete cover during pre-cast pipe production. Spacers with vertical clips are used when inserting the reinforcement cage into the existing internal formwork. Spacers with horizontal (side) clips allow the outer formwork to be pushed over the reinforcement cage, without causing edge buckling.

Reinforcement end support

The reinforcement end support consists of a cylinder made of fibre-reinforced concrete and a plastic dowel for the vertical fixing of the reinforcement. The plastic dowel automatically clamps the reinforcing bar when it is inserted.

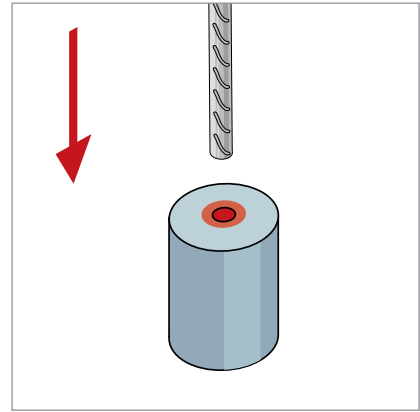

Tunnel spacers

Tunnel spacers are used in contact with waterproofing membranes. To reduce any potential for damage these spacers have a larger rounded support surface. The geometry and fixing method for this spacer ensure that the spacer remains in position during concreting.

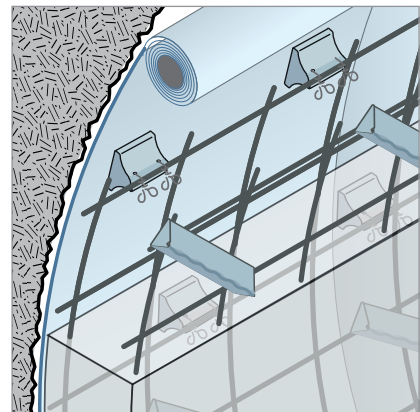

Sorp 10® – Sound absorbing spacer for thermally activated structural elements

Sorp 10® has a dual function of acting as a spacer to provide the requisite cover to the reinforcement plus a sound absorbing capability. The fibre concrete shell provides durable protection to the reinforcement, whilst the sound absorbing core damps down noise levels in office and administration buildings.

Sorp 10® is laid in rows at regular intervals and the reinforcement and cooling systems are then installed. These spacers have minimal influence on the thermal efficiency of the completed installation.

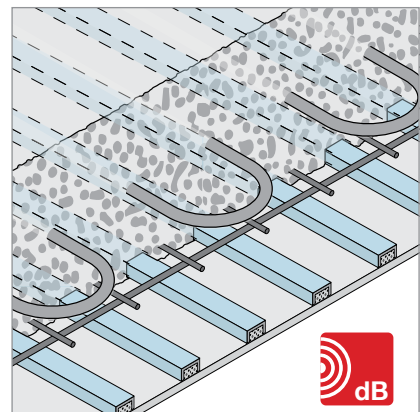

Development for your requirements

Based on our many years of experience, we'll be glad to develop solutions to suit your particular problem.

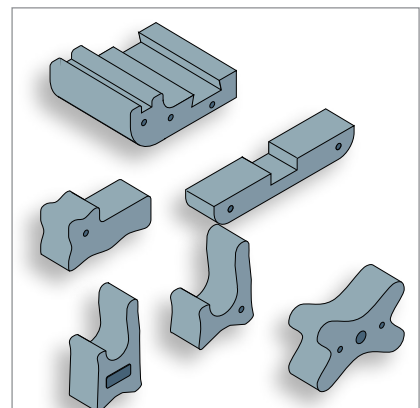



Fibre-reinforced concrete distance tubes

Distance tubes are used to guarantee concrete wall thickness using reusable tie bars.

Distance tubes are the perfect technical solution for shutter ties.

- High compressive strength
- Large contact area, therefore reduced pressure on the formwork
- Conforms to EN 1992-1-1:2011-01 (Eurocode 2) and DIN 18216 (formwork anchors for concrete formwork)
- Water resistant – the combination of various distance tube options with sealing stoppers and cones gives an impermeable shutter tie system that has been tested and certified according to EN 12390-8 (3 days at 5 bar water pressure)
- Fire resistance - helps to prevent the spread of fire and smoke in a fire event due to the use of tubes and sealing stoppers of fire resistance classes F30-F180, which are suitable for fire walls to F90 according to EN13501-1:2002
- Sound Proofing - helps to prevent noise transfer by the use of the tubes and appropriate stoppers

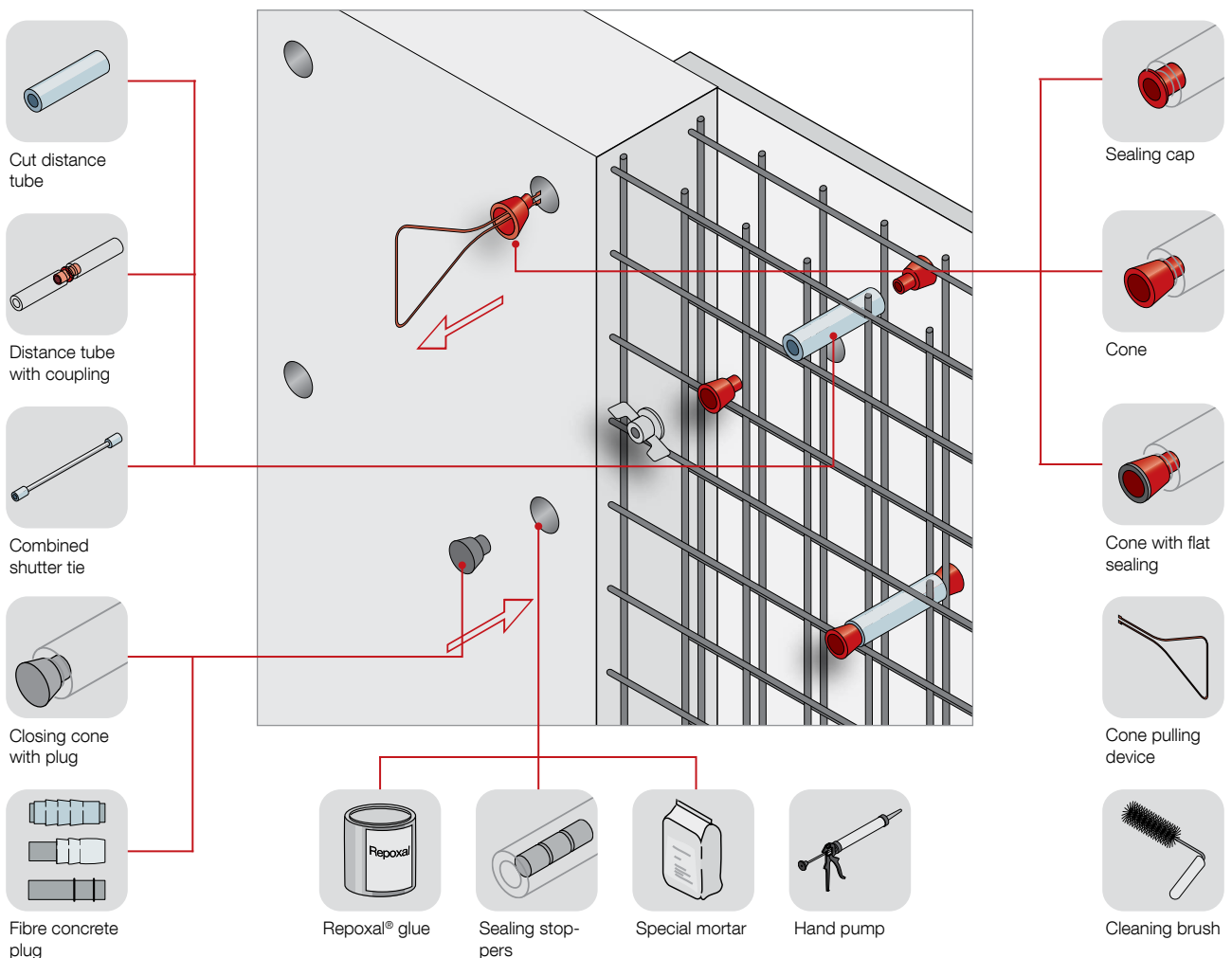



Material advantages

- Distance tubes made of fibre-reinforced concrete bond monolithically with the concrete, thus preventing the penetration of water. Distance tubes and cones made of fibre-reinforced concrete have a very high compressive strength.
- The stoppers and cones are glued using the tried-and-tested Repoxal®. This systems meets the requirements for noise insulation, fire protection and pressing water loads.
- Sealing cones provide for homogeneous, durable and aesthetically appealing concrete surfaces.

Different combinations of distance tubes are used, depending on the wall thickness. For maintenance of the specified wall thickness, the length of the selected cone or sealing cap must be included in the calculation together with the length of the distance tube. Dimensions can be found in the current MAX FRANK Product List to enable the correct choice of type; custom productions are also possible on enquiry.

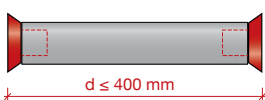

Distance tube, single section

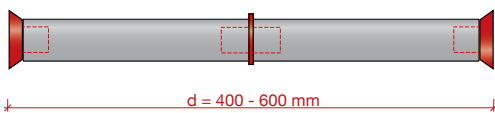

Distance tube, two sections with coupler

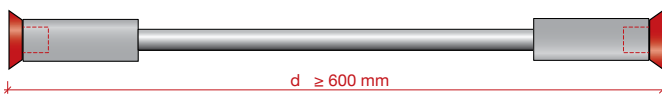

Composite distance tube of two lengths of fibre concrete tube with intermediate steel tube

Selection table tie bar

Distance tube Ø	Tie bar Ø nominal dimension
22	12.5
22	15.0
27	20.0
32	22.0

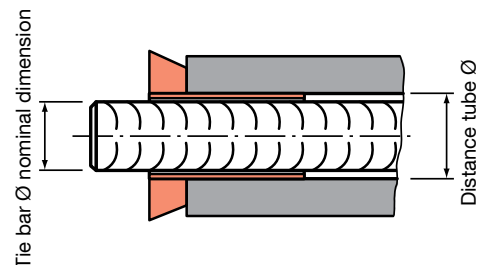

Assembly procedure

The use of distance tubes, installed with plastic sealing caps and cones and after formwork stripping sealed with fibre-reinforced concrete stoppers and cones, results in a tried and tested system that is suitable for the most diverse physical and chemical environments.

For architects and planners, who focus increasingly on exposed concrete, the large selection of sealing cones offers a wide variety of design possibilities.

Described below are the work steps required to ensure the optimum sealing of distance tubes.

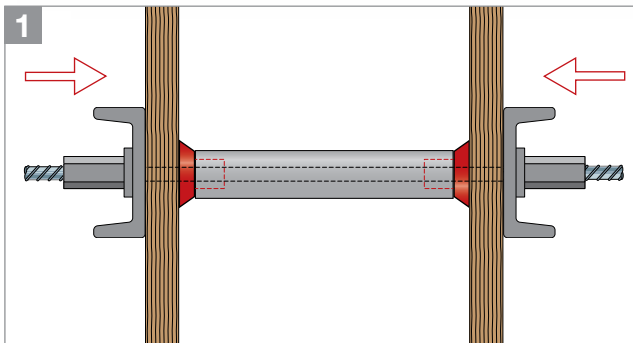

Formwork ties are located in a grid pattern to suit the layout and loading conditions of the formwork. At each location a fibre-reinforced concrete distance tube in combination with plastic sealing caps or cones is used to form a sleeve to ensure an exact wall thickness and to protect the reusable threaded anchor steel.

The fibre-concrete material of the distance tubes can absorb high compressive loads and the large contact area reduces pressure on the formwork face.

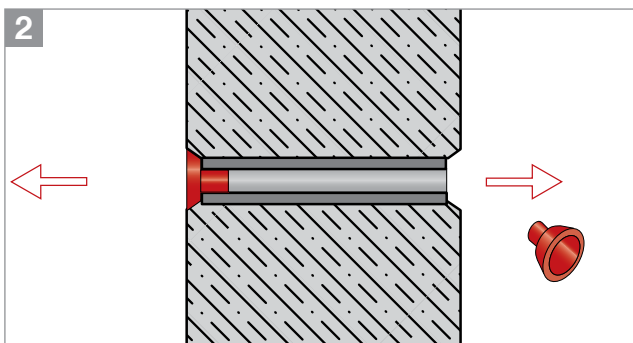

The use of a plastic sealing cap or cone compensates for any unevenness of the formwork surface and prevents the ingress of any cement slurry. Following demoulding, the plastic sealing cones are removed with the aid of a cone pull-out device. The installation depth of the distance tubes is increased if sealing cones are used, a permanent truncated cone-like recess remains.

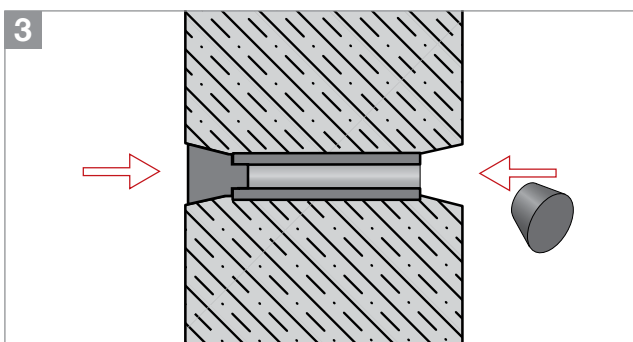

MAX FRANK offers a wide range of concrete sealing cones with different shapes, textures and colours. Apart from the fibre-reinforced concrete versions, cones are also available in a cast concrete version.

The cones are glued with a precise fit on both sides using the Repoxal® two-component glue. The tried-and-tested Repoxal® TW is the ideal solution for the fast, clean sealing of tie holes in the drinking water sector.

Plastic sealing cap

The plastic sealing cap helps to distribute any pressure from the formwork evenly, accommodates small misalignments and seals the end of the distance tube to prevent the ingress of cement slurry. The distance tubes can be sealed with stoppers made of fibre-reinforced concrete, FB-Kombistop, FB-Aktivstop and FB-Easystop for the respective requirement. Concrete sealing caps complete the system.

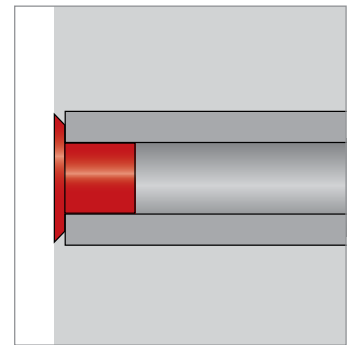
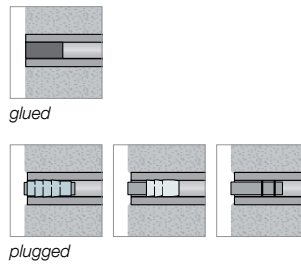

Plastic cone 1 cm

This cone can be used for the same applications as the sealing cap, but enables higher pressures to be absorbed and can compensate for larger weak points in the formwork such as unevenness or damage. Sealing with the various types of stoppers and cones complete the system.

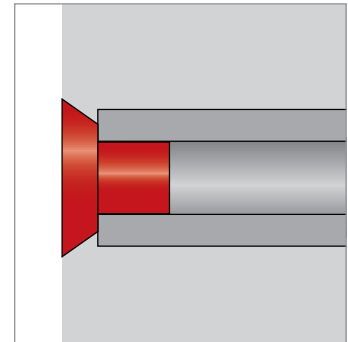
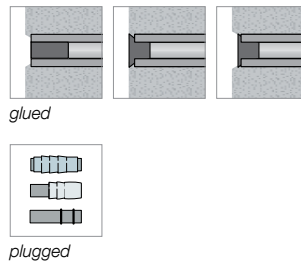

Plastic cone 3 cm

This cone can be used for the same applications as the 3 cm cone but can also be used where tensioning is not at right angles to the formwork. The cone can be cut on site to suit the required angles. Sealing with the various types of stoppers and cones complete the system.

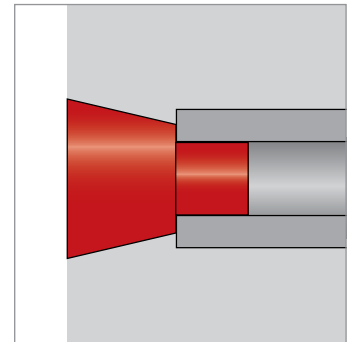
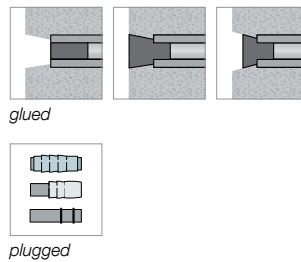

Plastic cone 5 cm

This cone can be used for the same applications as the 3 cm cone. Sealing with the various types of stoppers and cones complete the system. However, just one flush-fitting cone glued on both sides is sufficient to achieve a waterproof seal up to 5 bars.

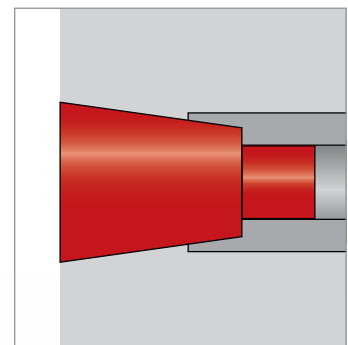
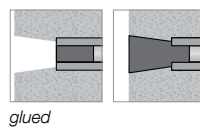

Flat gaskets

All our plastic sealing cones are delivered with a flat gasket made of an absorbent plastic. The porous seal between the face of the formwork and the sealing cap ensures a balanced water content at the surface. Surplus concreting water and air bubbles are drained away and the formation of concrete honeycombs is prevented.

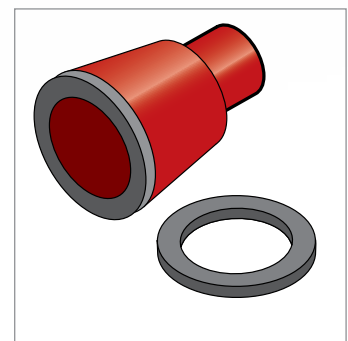



Sealing options

There are various options available for the sealing of fibre concrete distance tubes, depending upon structural requirements with regard to appearance, weathering and function. The sealing method should be agreed by the building owner and other interested parties at an early stage, since each sealing option requires a different hole shape.

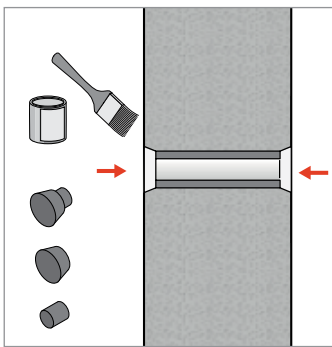

Gluing of fibre-reinforced concrete stoppers and cones

The watertight sealing of tie-bar holes is created using MAX FRANK distance tubes is accomplished using glued-in fibre reinforced concrete stoppers. Gluing using the tried-and-tested Repoxal® glue produces a flush closure. In combination with MAX FRANK sealing cones, the tie-bar hole can be used as an element in exposed concrete surfaces. Flush versions or versions with shadow gaps are ideally suited to this.

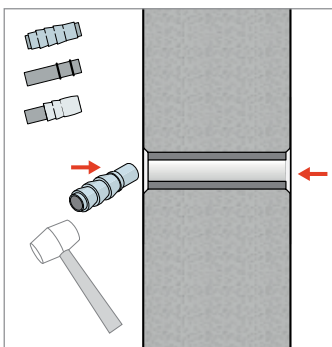

Fibre-reinforced concrete sealing stoppers

In addition to the glued sealing stopper, MAX FRANK also offers the following for the sealing of tie-bar hole:

- FB-Kombistop with integrated rubber seal,
- FB-Easystop with integrated sealing rings and
- FB-Aktivstop with integrated expanding seal.

The various sealing stoppers cover the different requirements for the sealing of distance tubes with regard to building physics and conditions of use (see page 28/29). The simple sealing can be carried out in all weathers, enabling work to continue immediately.

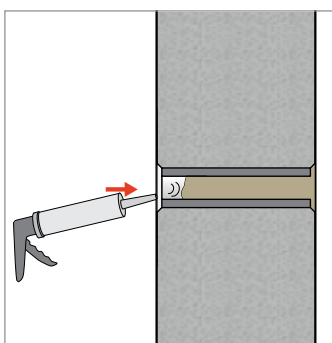

Grouting with expanding mortar

The special non-shrink mortar 3/25 can also be used to completely fill distance tubes. With the aid of the manual grouting gun, the special mortar is quickly injected into the tie-bar hole and, after trowelling with a float, a closed surface appearance is obtained.

FB-Kombistop with integrated rubber seal

The FB-Kombistop is a fibre-reinforced concrete sealing stopper enclosed in silicone rubber. This material combination enables the waterproof sealing of distance tubes by simply tapping in the stopper with a rubber mallet. The simple sealing of the distance tubes can be carried out at any time and enables work such as backfilling and water filling to commence immediately.



FB-Aktivstop with integrated expanding seal

The FB-Aktivstop is a fibre-reinforced concrete sealing stopper enclosed in an expanding material. This material combination enables the waterproof sealing of distance tubes by simply tapping in the stopper with a rubber mallet. As a custom version, the Aktivstop Platinum 100 can be used to seal the conical anchor opening of the Platinum 100 formwork from the Hünnebeck company. It is tapped in from the inside on the side facing away from the water. The properties correspond to those of the standard version of the Aktivstop.



FB-Easystop with integrated sealing rings

This material combination enables the sealing of distance tubes for rising structural elements above the basement level. They are simply screwed in by hand. The simple sealing of the distance tubes can be carried out at any time and enables work such as backfilling and water filling to commence immediately. The simple sealing of the distance tubes are also suitable for exposed concrete.



Fibre-reinforced concrete sealing stopper with Repoxal®

The gluing of the stopper with Repoxal® glue satisfies the requirements for noise insulation, fire protection and pressing water loads. Use is possible in the drinking water sector with Repoxal® TW glue. After installation, backfilling and water filling should be delayed until the glue has hardened



Stoppers in standard formats

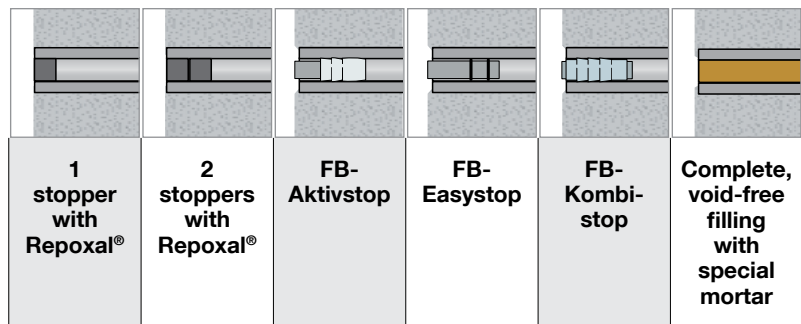

Properties:

		1 stopper with Repoxal®	2 stoppers with Repoxal®	FB-Aktivstop	FB-Easystop	FB-Kombi-stop	Complete, void-free filling with special mortar
Pressing water		not tested	5 bar	5 bar	⊖	5 bar	not tested
Fire protection		F30	F30-F180	not tested	not tested	not tested	F90 Fire wall
Noise insulation		not tested	yes	not tested	not tested	not tested	yes
Installation in frosty weather		⊖	⊖	⊕	⊕	⊕	⊖
Drinking water		⊕	⊕	⊖	⊖	⊕	⊖
Appearance				⊖		⊖	⊖

Stress:

Salt water	⊕	⊕	⊕	⊕	⊖	⊕
Acids/alkalis	○	○	⊕	○	○	○
Liquid manure	○	○	⊕	○	⊖	○
Hydrocarbons	○	○	⊖	○	⊖	○
Crude oil/mineral oil	○	○	⊖	⊕	⊖	○

⊕ suitable ○ conditionally suitable ⊖ not suitable

Remarks

1) For a through-seal without hollow space, in combination with two stoppers

Sampling with the building owner is recommended with regard to appearance and dimensions.

Standard colours

The colour gradations 3H, 1H, Standard and 4D are available as basic colours for sealing cones made of fibre-reinforced concrete and cast concrete. Colour accuracy cannot be guaranteed on account of fluctuations in the natural raw materials.

Recessed variants are recommended, since the colour gradation is emphasised by the shadow joint of the geometric grid of the clamping points.

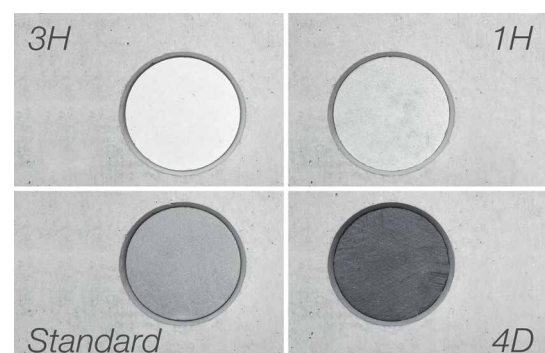

Cone

Custom formats

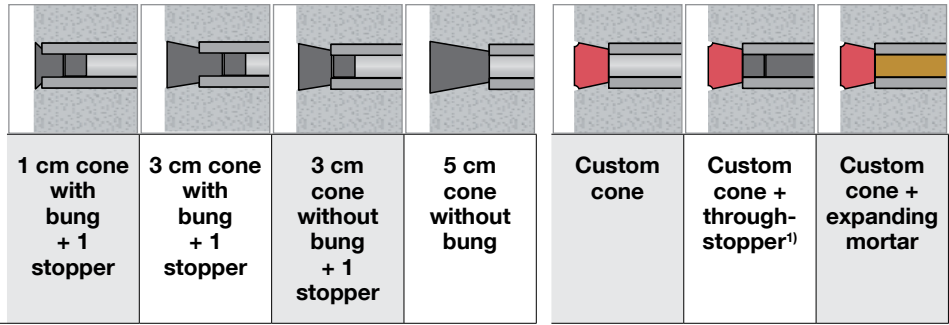

Properties:

Pressing water		5 bar	5 bar	not tested	5 bar
Fire protection		F30-F180	F30-F180	F30-F180	F30-F180
Noise insulation		yes	yes	yes	yes
Installation in frosty weather		⊖	⊖	⊖	⊖
Drinking water		⊕	⊕	⊕	⊕
Appearance					

Optik

Stress:

Salt water	⊕	⊕	⊕	⊕
Acids/alkalis	○	○	○	○
Liquid manure	○	○	○	○
Hydrocarbons	○	○	○	○
Crude oil/mineral oil	○	○	○	○

⊕ suitable ○ conditionally suitable ⊖ not suitable

Appearance

Optically very high quality execution (sampling is recommended).

Optically high quality execution with standard cones

Optically normal execution

⊖ *Not optically suitable as "exposed concrete"*

Custom colours

Based on the four basic colours, a variety of other shades of grey are available for sealing cones. This also applies to other colours, such as reds, yellows or browns. A project-related colour match is required for this.

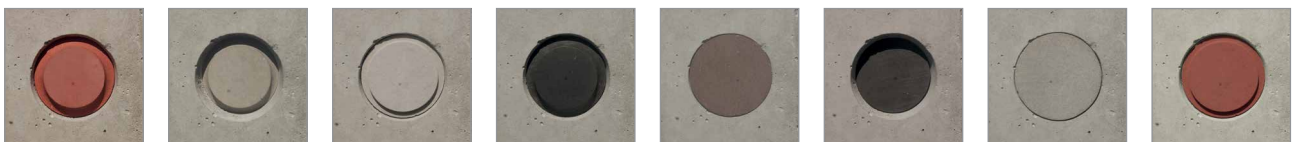

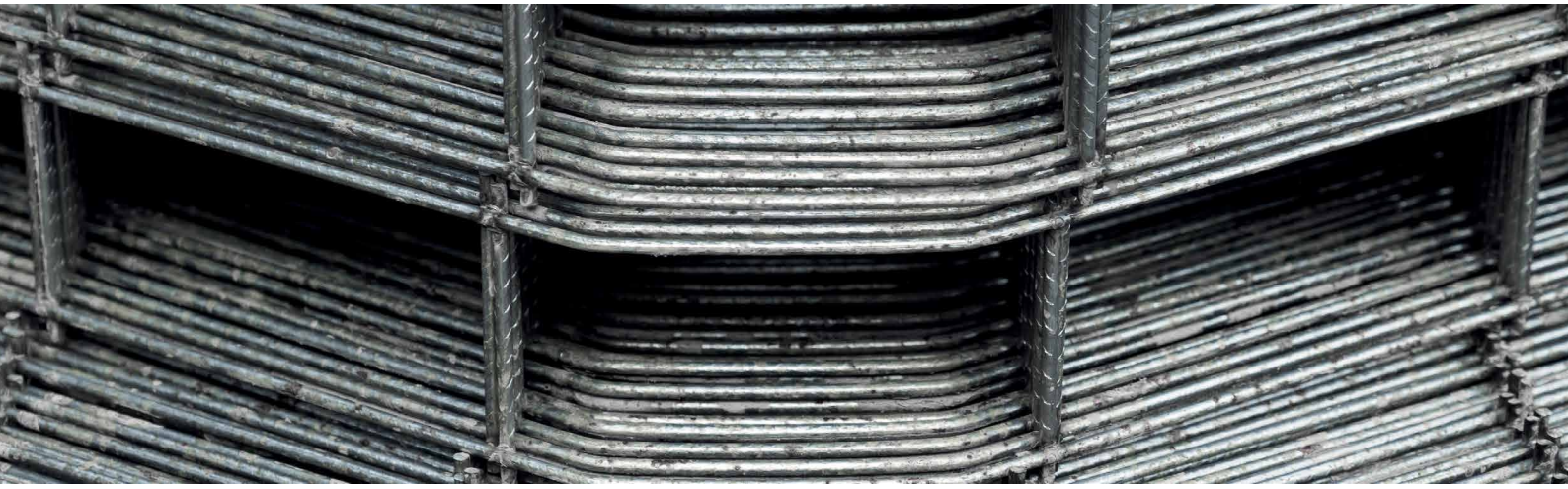

Steel spacers – U-Korb® wire spacer

Steel spacers are used between the lower and upper reinforcement in the floor, ceiling and wall. They ensure the spacing between the reinforcement layers. This type of spacer is ideally suited for installation of mats and steel bar reinforcements.

- Tested according to DBV leaflet “Supports” according to Eurocode 2
- Large support area prevents tipping
- No contact with the formwork, therefore no damage to the formwork skin and no rust stain formation

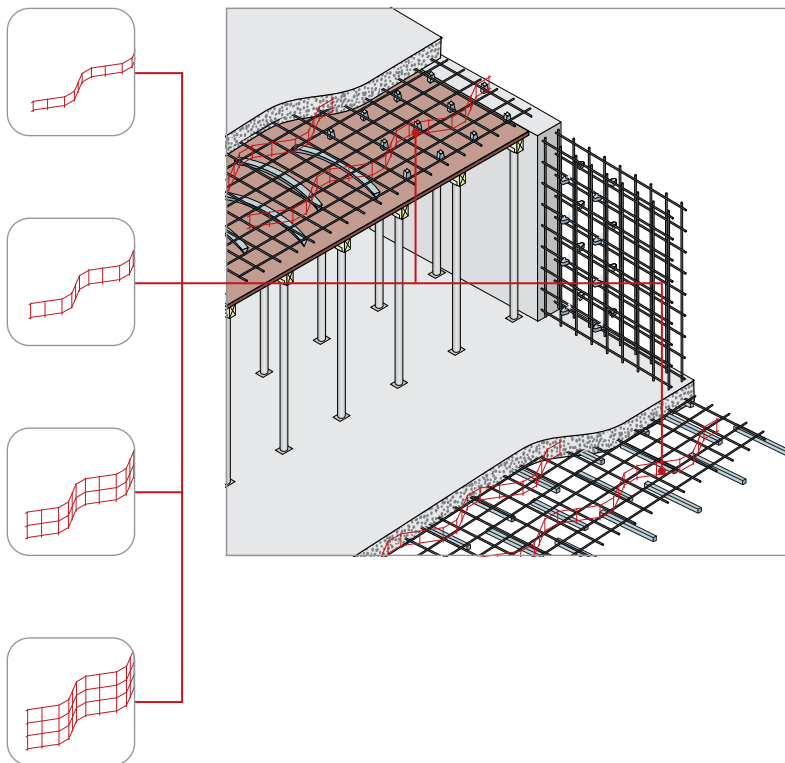

Determination of the necessary U-Korb® size:

Determination of the necessary U-Korb® size, taking into account the required concrete cover and the desired ceiling thickness:

		Example:
1. Concrete cover of the lower reinforcement	a1	30 mm
2. Concrete cover of the upper reinforcement	a2	20 mm
3. Overall height of the lower reinforcement*	b1	15 mm
4. Overall height of the upper reinforcement*	b2	15 mm
	Total x	80 mm

Desired ceiling thickness "d" minus total "x" = necessary U-Korb® height "h".
In our example for a desired ceiling thickness of 200 mm: $200 - 80 = 120$ mm.
U-Korb® height corresponds to UKS12.

*please take into account the mat overlapping joints

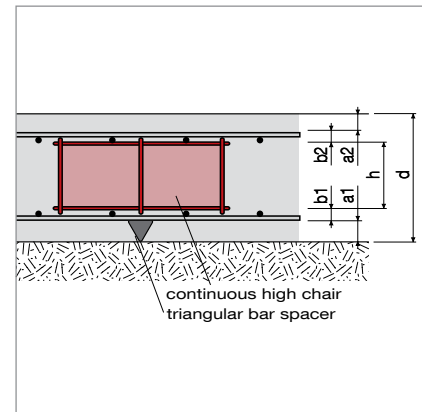

Required information when ordering continuous high chairs:

The following number of continuous high chairs are required for normal construction loadings:

Bar diameters	Placing interval s	Approx usage/m ²
$\varnothing \leq 6.5$ mm	500 mm	1.0
$\varnothing > 6.5$ mm	700 mm	0.7

This table can only be used as a guideline for determining requirements. The load-bearing capacity corresponds to the load of a normal reinforcement. Additional loads, above all point loads, cannot be transmitted.

The exact installation spacing must always be adapted to the requirements of the reinforcement and the concrete cover and must be checked on site. Decisive above all are the acceptable deflections when walking on the reinforcement (concreting).

In the case of reinforcement structures that are not walked on, e.g. when using the U-cage in wall structures, the determined requirement can be reduced by 10 to 20%.

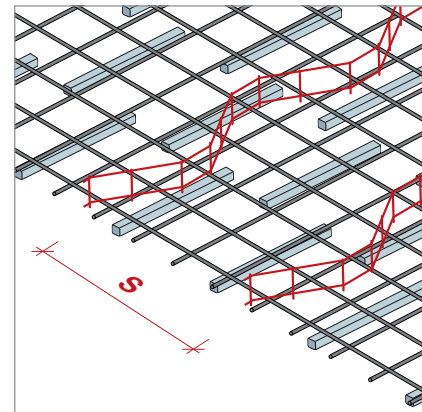



MAX FRANK BUILDING
COMMON GROUND

MAX FRANK Group

Headquarter:

Max Frank GmbH & Co. KG

Mitterweg 1

94339 Leiblfing

Germany

www.maxfrank.com

