

BUILDING
COMMON GROUND



Egcodorn[®] & Egcodubel

Shear force dowel for expansion
joints







BUILDING
COMMON GROUND



Egcodorn® & Egcodubel

Shear force dowel for expansion joints

Contents

Applications	4
Product overview	5
Explanations	6
Egcodorn® WN/WQ, N/Q shear force dowel	8
Technical Information	10
Accessories	11
Standard types	12
Design	13
Application guidelines	26
Project	27
Egcodorn® SWN/SWQ shear force dowel	28
Design	30
Application guidelines	34
How to	35
Egcodubel shear force dowel	36
Type overview	38
Accessories	40
Design	41
Application guidelines	45
Egcodorn® DND shear force dowel	46
Egcopal impact sound insulated shear force dowel ..	48
Egcodorn Software 2.0	50

Egcodorn® WN
for longitudinal
movement

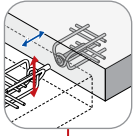

Egcodorn® WQ
for longitudinal
and transverse
movement

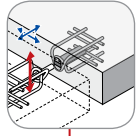

Egcodorn® SWN
for longitudinal
movement

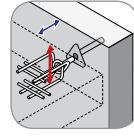

Egcodorn® SWQ
for longitudinal
and transverse
movement

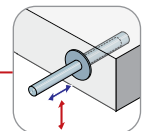
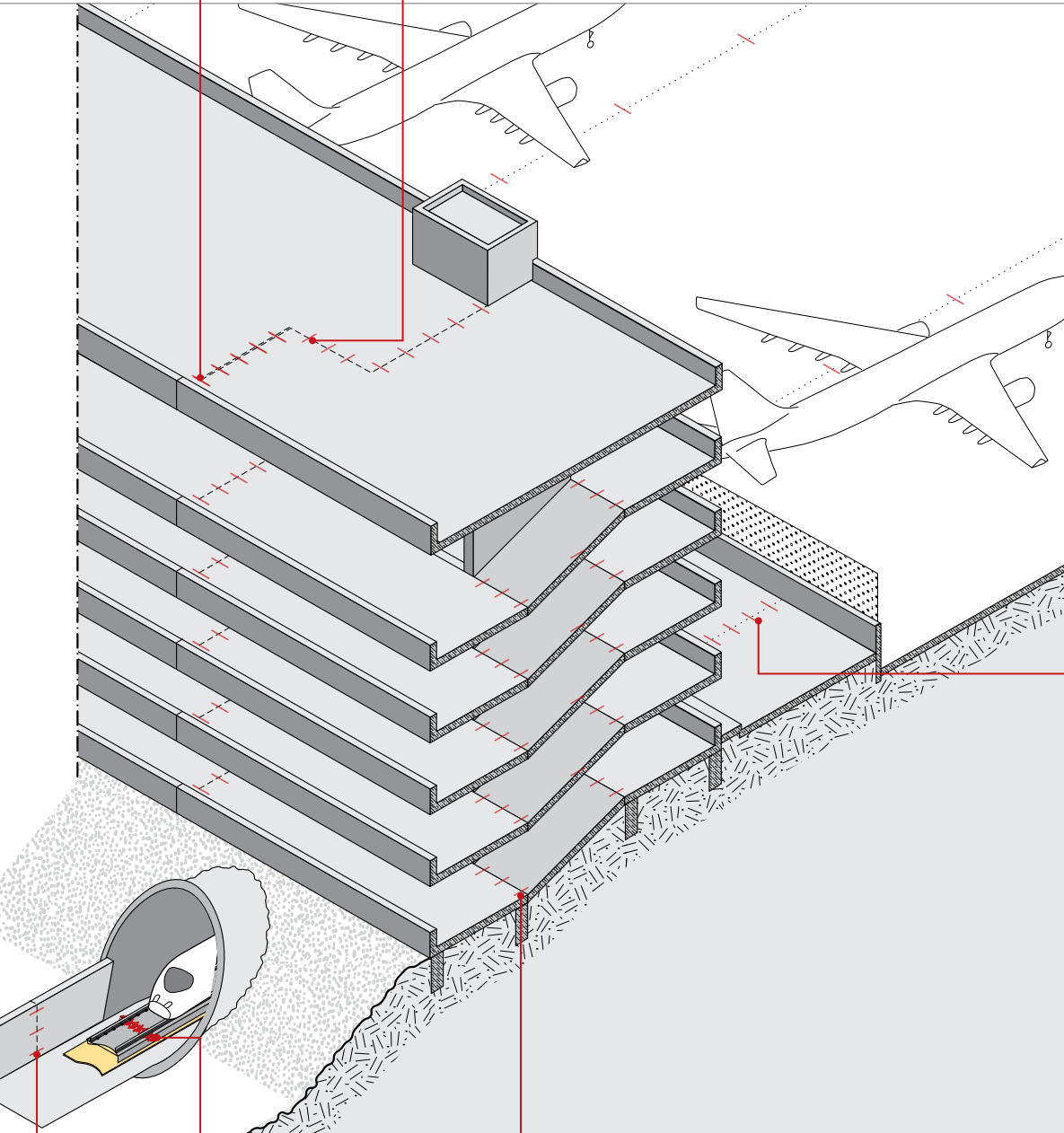
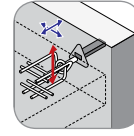

Egcodubel for
longitudinal
movement

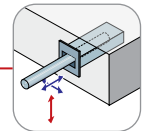

Egcodubel for
longitudinal
and transverse
movement

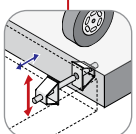

Egcodorn®
DND

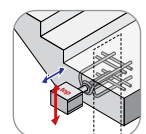

Egcopal

Egcodorn® WN/WQ, N/Q

for high loads

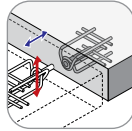

Egcodorn® WN
for longitudinal
movement

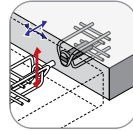

Egcodorn® WQ
for longitudinal
and transverse
movement

Egcodorn® SWN/SWQ

for wall application

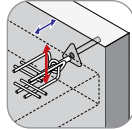

Egcodorn® SWN
for longitudinal
movement

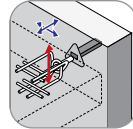

Egcodorn® SWQ
for longitudinal
and transverse
movement

Egcodubel

for small to medium loads

with sleeve

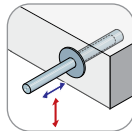

Egcodubel for
longitudinal
movement,
stainless steel
sleeve

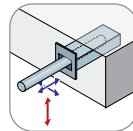

Egcodubel for
longitudinal
and transverse
movement, stainless
steel sleeve

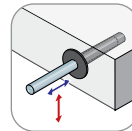

Egcodubel for
longitudinal
movement,
plastic sleeve

without sleeve

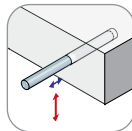

Egcodubel
stainless steel/
galvanised

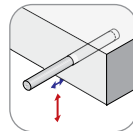

Egcodubel
galvanised and
coated

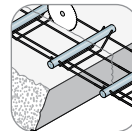

Egcodubel
dowel bedding

Egcodorn® DND

for dynamic loads

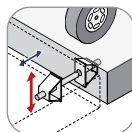

Egcodorn®
DND

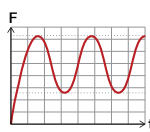

More information can be found in our Egcodorn® DND brochure.

Egcopal

Impact sound insulated shear
force dowel

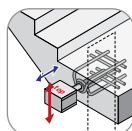

Egcopal



More information can be found in our Building Acoustics brochure.

Explanations

Advantages of dowel connections

Expansion joints prevent the restraint that occurs with hindered deformation by allowing time-dependent deformations. A correspondingly smaller amount of surface reinforcement is necessary. The forces perpendicular to the direction of movement are absorbed by dowel connections.

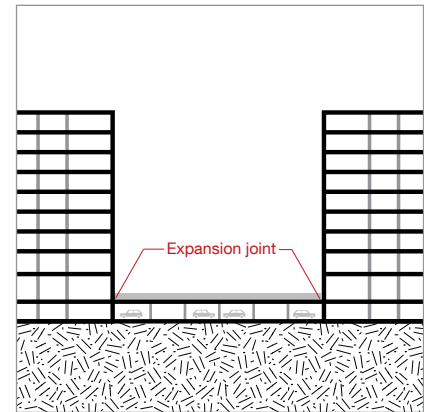

Advantages	Conventional execution	Dowel connection
Reinforcement layout and shuttering work are considerably simplified with dowel connections.		
Unlike with the conventional execution, shear forces can be positive and negative.		
With regard to the joint arrangement directly by the wall, dowel connections offer aesthetic advantages.		
The execution with dowel connections speeds up the construction process considerably and facilitates both the shuttering work and, in connection with foundation slabs, the excavation – that effectively saves costs.		
Twin walls can be dispensed with, allowing more space to be provided inside the building.		

Typical connection situations

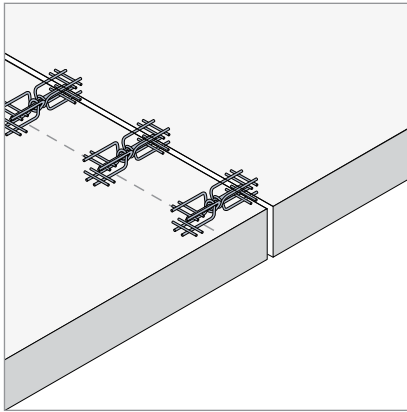

slab / slab

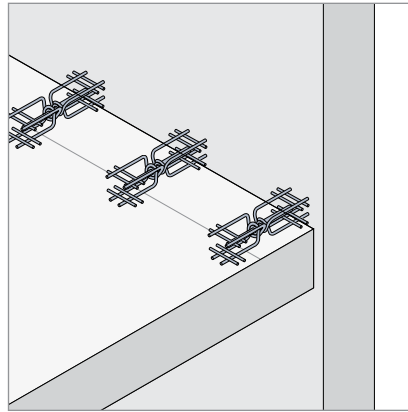

wall / slab

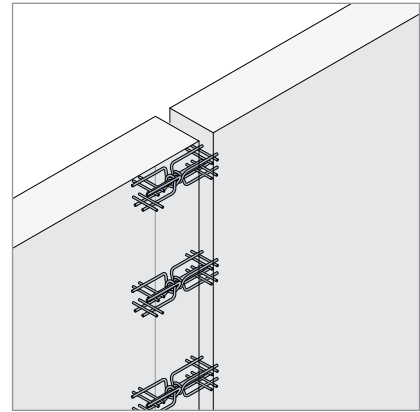

wall / wall

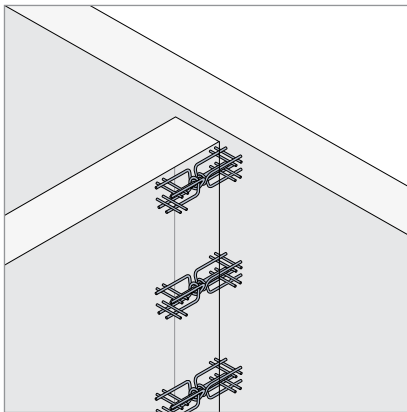

wall / wall

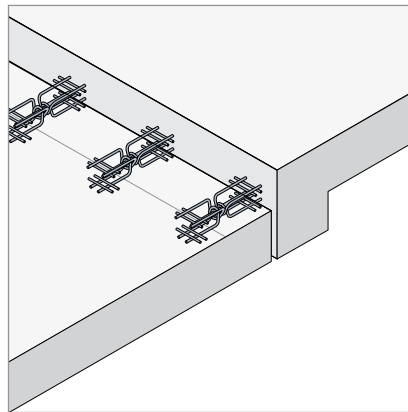

beam / slab

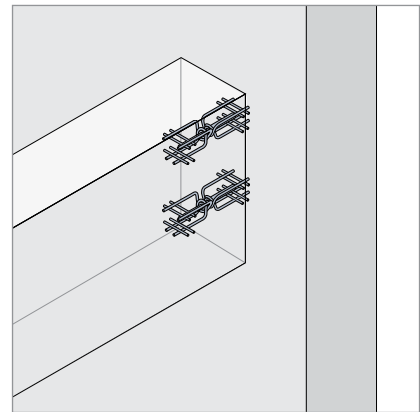

wall / beam

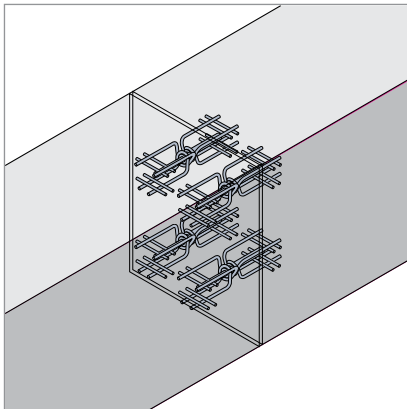

beam / beam



BUILDING
COMMON GROUND

Egcodorn®

WN/WQ, N/Q shear force dowel
for high loads

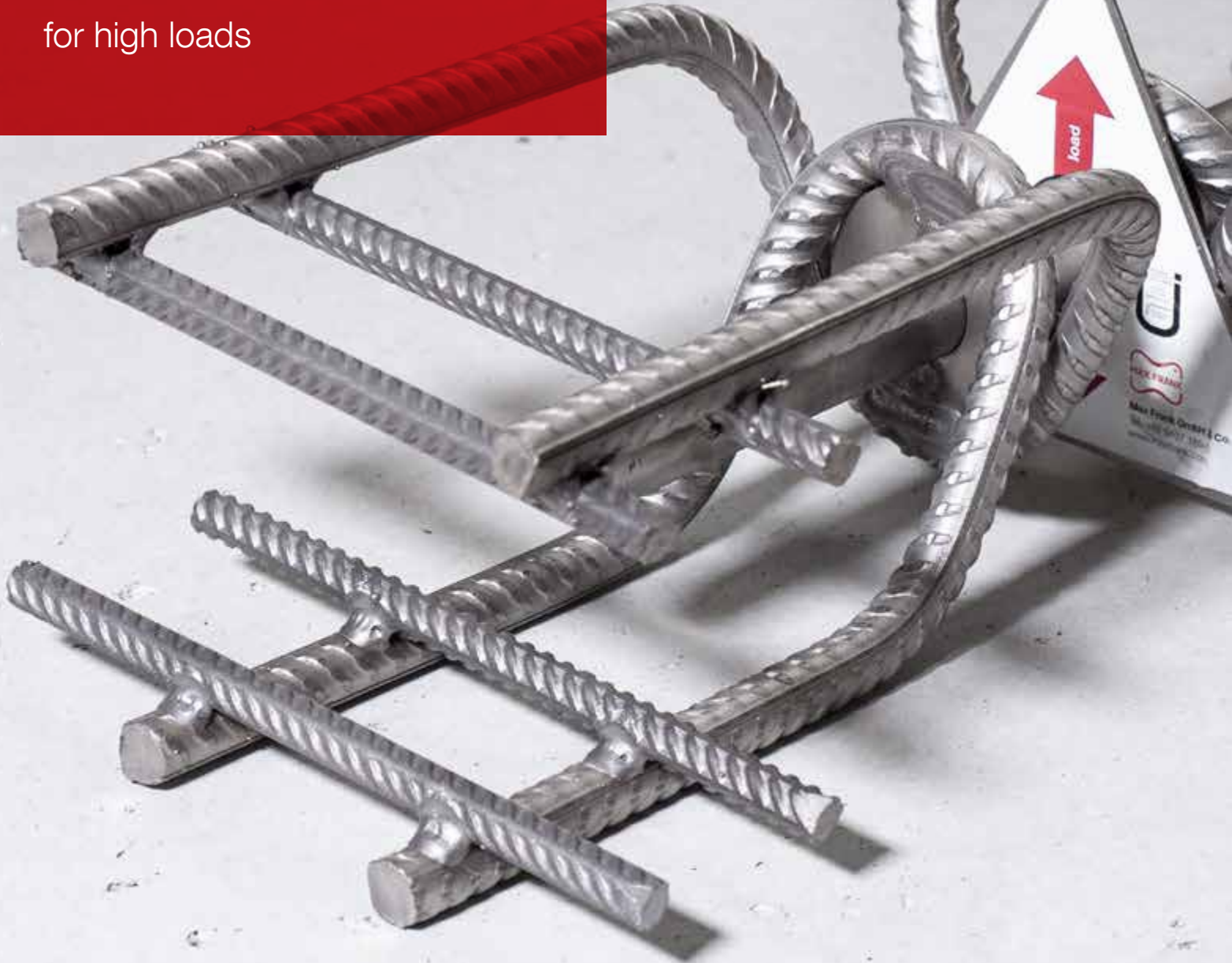

Egcodorn® WN/WQ, N/Q shear force dowel

for high loads

The Egcodorn® shear force dowel transmits maximum forces with minimum component thicknesses and is used with primarily static loads. The use of high-quality materials, the unique corrosion protection system and the German National Approval guarantee maximum safety.

The **longitudinally moveable** Egcodorn® WN, N allows displacements in the direction of the longitudinal dowel axis.

The **laterally moveable** Egcodorn® WQ, Q must be used if displacements occur transversely to the dowel axis. It allows displacement in both directions. This Egcodorn® type is recommended with curved component edges or long joint lengths.

For more economical solutions, material utilization can be optimized with the Egcodorn® modular system.

★ Advantages

- High loads with small component thicknesses
- Large joint width up to 80 mm approved
- Made of stainless steel for high corrosion protection
- Fire protection R120 with fire protection collar
- German National Approval DIBt Z-15.7-301
- Simple installation and fastening thanks to open design
- Design software
- Technical support
- BIM data available

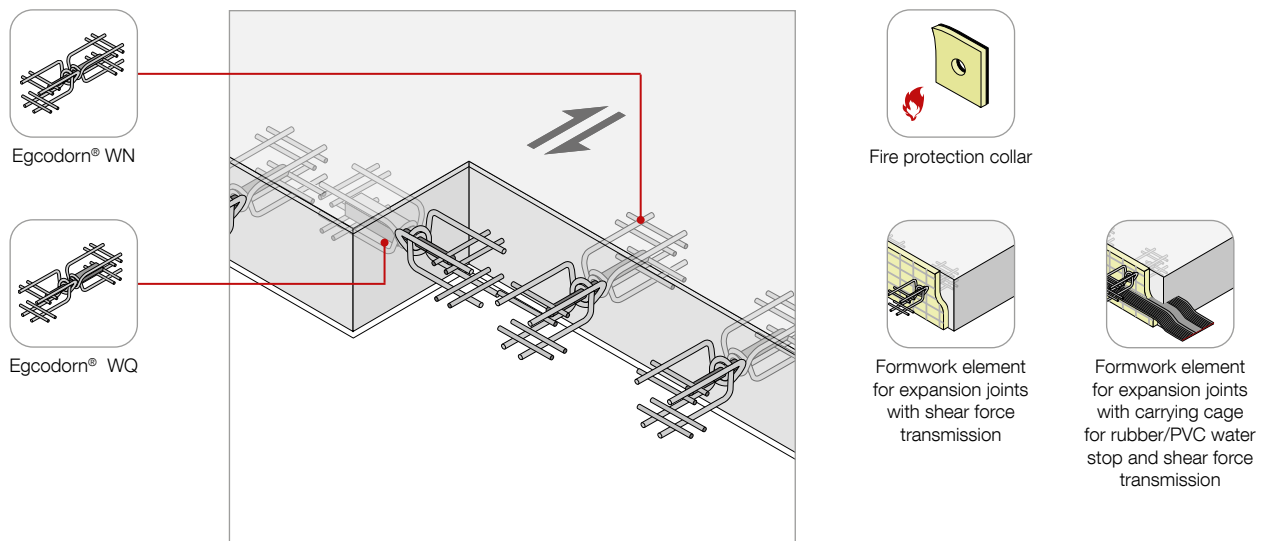

Technical Information

Load-bearing behaviour

The shear forces occurring in the joint are absorbed by the dowel and reliably transmitted into and anchored with the associated anchor body. The full anchorage of the occurring forces is secured with concrete qualities of C20/25 or higher.

Depending on the type selected, displacements are allowed exclusively in the longitudinal dowel direction (Egcodorn® WN, N) or in the horizontal transverse direction to the dowel (Egcodorn® WQ, Q).

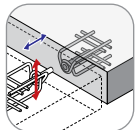

Egcodorn® WN
for longitudinal
movement

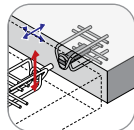

Egcodorn® WQ
for longitudinal and
transverse movement

The dowel and anchor body of the Egcodorn® are matched to typical construction boundary conditions. Depending on the desired load-bearing capacity and geometric boundary conditions, a suitable Egcodorn® can be selected from the standard range. Moreover, it is possible to optimise the dowel connection for the individual application with the Egcodorn® modular system.

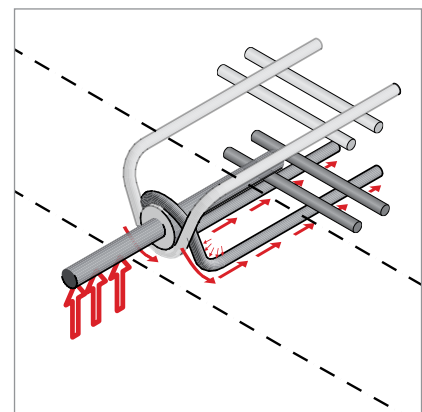
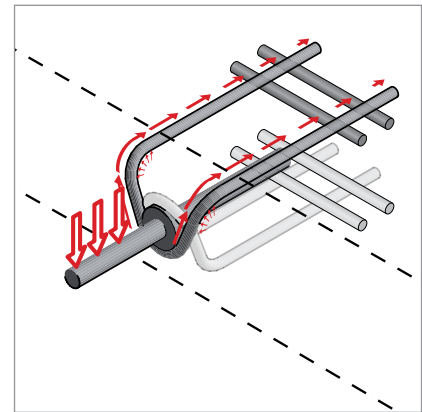

Corrosion protection

With the core-jacket system, the Egcodorn® combines the outstanding mechanical properties of the high-strength load-bearing dowel core with the excellent corrosion protection of the stainless steel jacket (corrosion resistance class III). During the mechanical processing the surface is tempered, which leads to particularly favourable sliding properties.

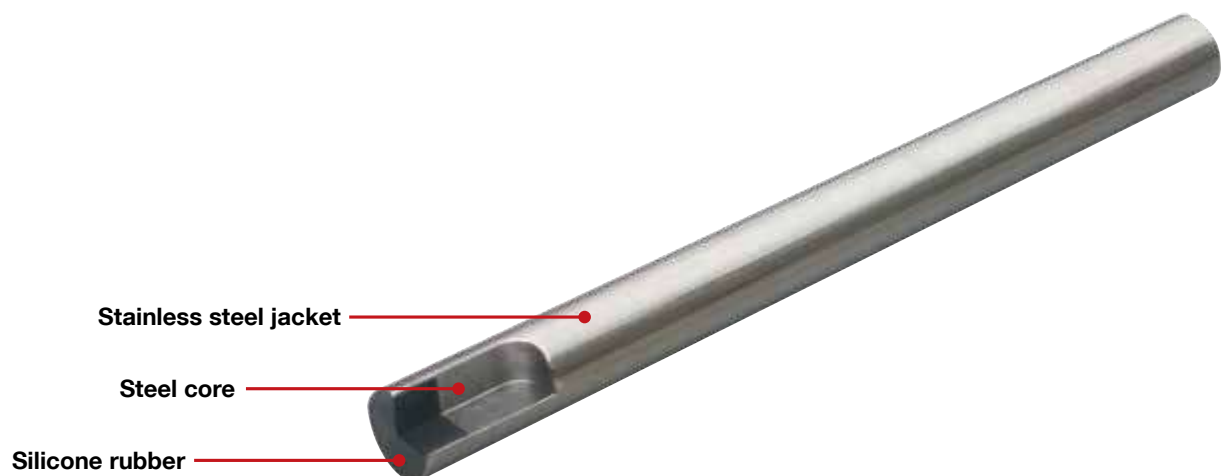

Accessories

Fire protection collar

If there are fire protection requirements to be met, the Egcodorn® shear force dowels can be protected with the optionally available fire protection collar; the classification is then R120. The suitable fire protection collar is selected in relation to the dowel type and joint width, as standard 20 to 60 mm. The air gap between fire protection collar and concrete surface must be no wider than 10 mm.



Installation

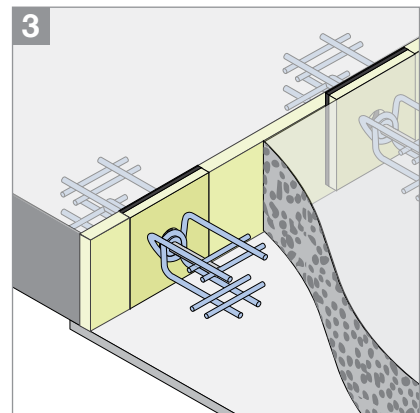
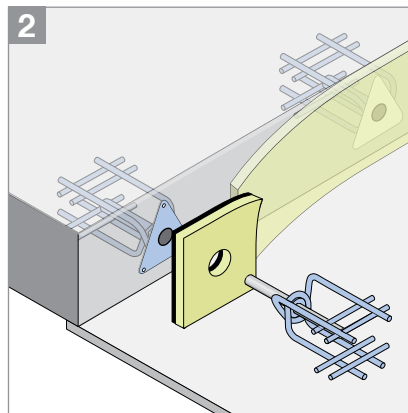
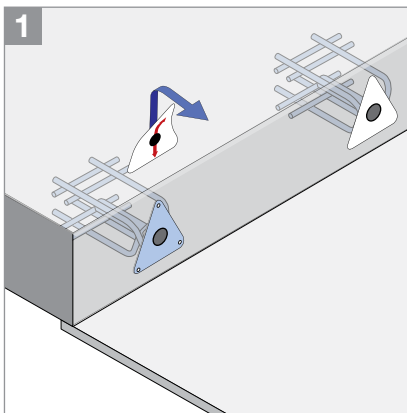

Standard types

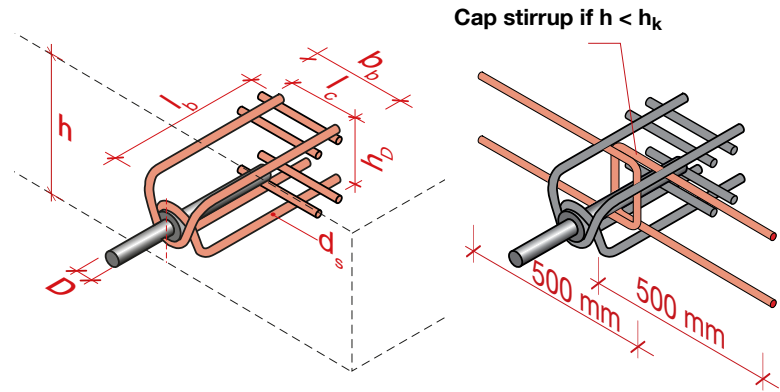

Dimensions

Standard type	WN / WQ											N / Q
	40	50	70	95	100	120	150	210	300	350	400	
External diameter of dowel D [mm]	22	24	27	30	32	34	37	42	44	52	52	
Height of anchor body h_D [mm]	80	100	120	140	140	170	170	200	240	240	240	
Length of anchor body l_b [mm]	156	187	218	250	250	312	312	390	390	390	1030	
Width of anchor body b_b [mm]	140/173*	187	200	222	222	261	261	308	330	330	268	

*Anchor body sleeve WQ

Application

Standard type	WN / WQ											N / Q
	40	50	70	95	100	120	150	210	300	350	400	
Minimum slab thickness h_{min} [mm]	140	160	180	200	210	230	250	280	300	350	350	
Minimum component depth $t_w^{(2)}$ [mm]	185	207	238	270	270	332	332	410	410	410	1050	
Minimum component width b_w [mm]	220	240	280	300	320	340	380	420	460	520	520	
Minimum edge distance a_r [mm]	70	80	90	100	105	115	125	140	150	175	175	
Minimum edge distance a_{r1} [mm]	110	120	140	150	160	170	190	210	230	260	260	
Calc. value for column width l_c [mm]	100	100	115	130	130	165	165	210	210	210	210	
Height $h_k^{(3)}$ [mm]	220	240	260	290	300	320	340	380	400	410	440	
Cap stirrup diameter [mm]	6	6	6	6	6	8	8	10	10	12	12	

Minimum reinforcement for local load introduction (anchoring outside the punching shear cone)

Standard type	WN / WQ											N / Q
	40	50	70	95	100	120	150	210	300	350	400	
Pos. 1: U-stirrups in dowel direction, 2 per side	Ø10	Ø10	Ø10	Ø12	Ø12	Ø14	Ø14	Ø16	Ø20	Ø20	Ø20	
Maximum spacing s_x [mm]	30	30	30	50	50	70	70	90	100	100	100	
Pos. 2: Edge reinforcement transverse to dowel [$n \cdot \text{Ø } d_{sy}$], top and bottom	1Ø10	1Ø10	1Ø10	1Ø12	1Ø12	1Ø14	1Ø14	1Ø16	1Ø20	1Ø20	1Ø20	

1) Core diameter = external diameter - 2 mm

2) Assumption: $c_{nom} = 20$ mm

3) A cap stirrup is to be used if the slab thickness h is $< h_k$

Standard joint width $z \leq 60$ mm; joint width $z \leq 80$ mm on enquiry

Custom Egcodorn® versions on enquiry, see also Egcodorn® modular system p. 13

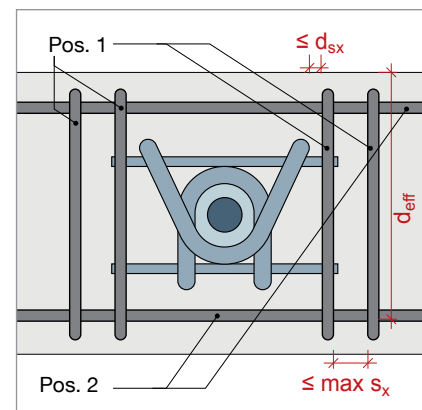
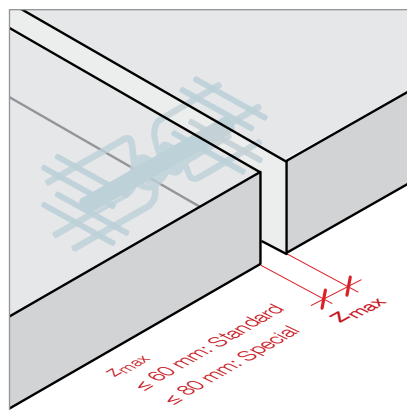
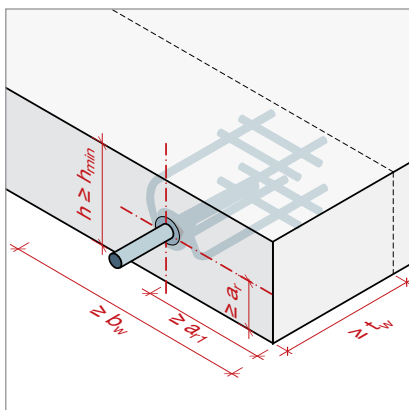

Egcodorn® modular system

The dowel and anchor body of the Egcodorn® are utilised differently depending on the acting shear force and the joint width. Moreover, specified component dimensions may restrict the type selection. With the Egcodorn® modular system the dowel connections can be configured to suit the respective conditions, thus also increasing the cost-effectiveness – just ask us.

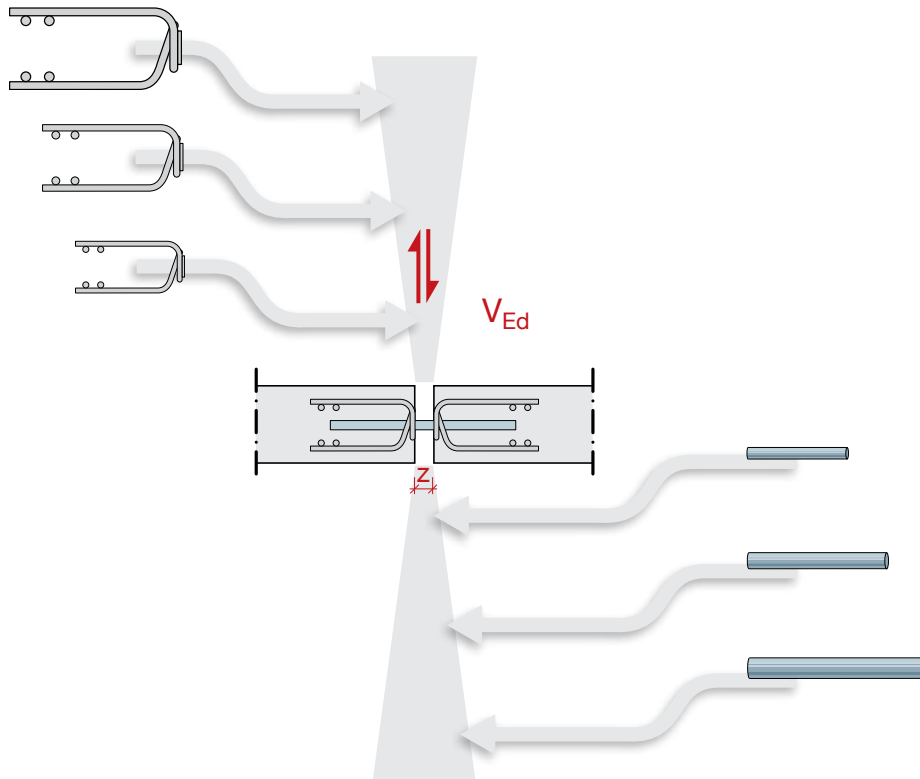

Design

The load-bearing capacity V_{Rd} of the dowel connection is limited on the one hand by the product load-bearing capacity $V_{Rd,s}$ of the selected Egcodorn® and on the other by the concrete load-bearing capacity $V_{Rd,rc}$.

$$V_{Rd} = \min \begin{cases} V_{Rd,s} \\ V_{Rd,rc} \end{cases}$$

The total component thickness is activated for the load transfer with the minimum reinforcement according to page 12. Subsequently, it must be proven that the component can resist the high single loads. If the dowel spacings and edge distances are sufficient ($e \geq e_{crit}$), undisturbed punching cones can form and the load-bearing capacity may be proven with the punching shear proof according to Eurocode 2. If the punching cones overlap ($e < e_{crit}$), the shear force proof according to Eurocode 2 is to be provided. The application of punching shear and shear reinforcement is permissible and enables high load-bearing capacities with a low total amount of reinforcement. On account of the design of the Egcodorn®, the proof of resistance to concrete edge failure is automatically fulfilled and need not be provided.

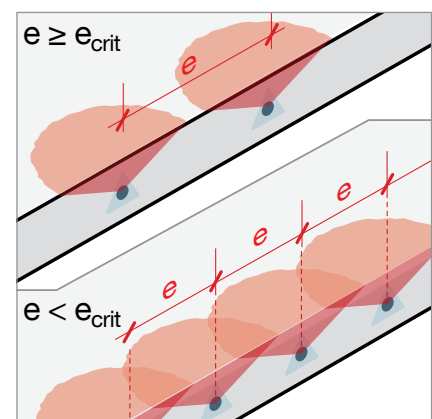
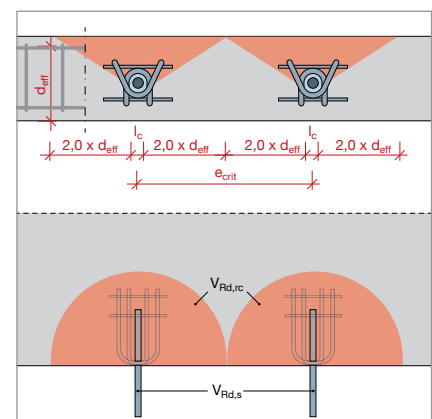

General procedure – design of slabs

The suitable Egcodorn® shear force dowels and the corresponding dowel spacings are selected according to the component properties, action and joint width. The load-bearing capacity of the slab in the load application area is then checked with these boundary conditions, with the application of the punching shear or shear force resistance proof depending on the dowel spacing, wherein provision may be made for punching shear or shear reinforcement.

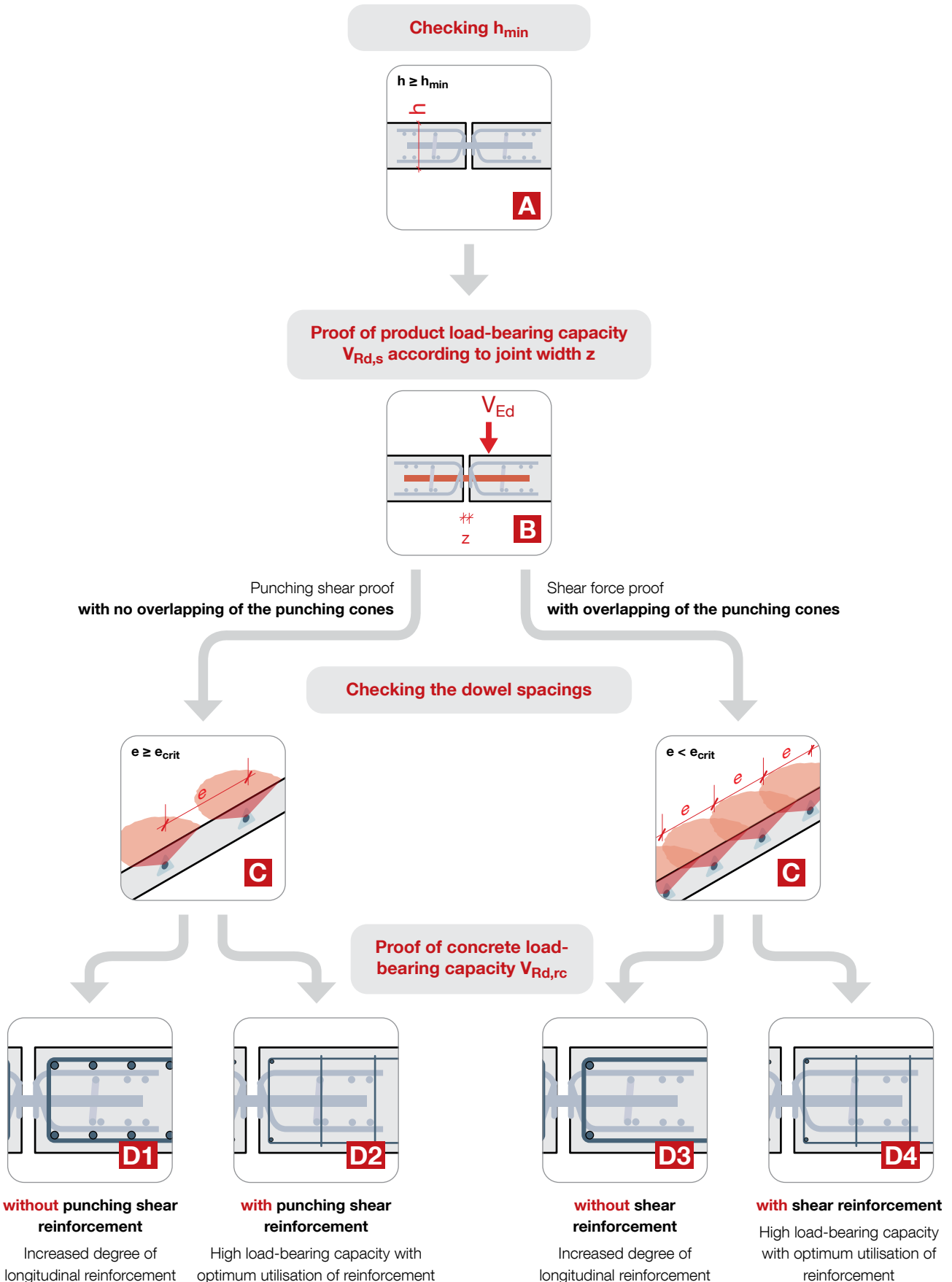

A Checking h_{min}

The suitable Egcodorn® is selected according to the existing component geometry. Particular attention must be paid to h_{min} with slabs.

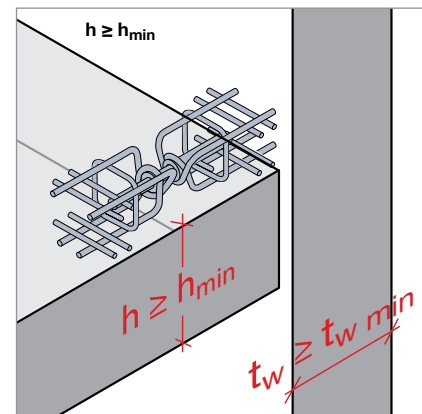

B Proof of product load-bearing capacity $V_{Rd,s}$ according to joint width z

On the basis of the specified joint width z and the design loads V_{Ed} , the dowel spacings can now be defined and the proof of the product load-bearing capacity $V_{Rd,s}$ can be provided for the Egcodorn®. The respectively maximum occurring joint opening is to be taken as the joint width z.

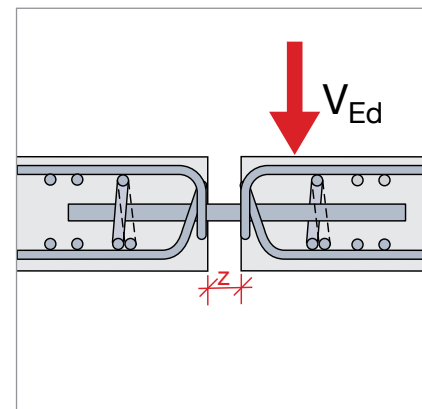

C Checking the dowel spacings

On the basis of the selected dowel spacings, you can now check whether the punching cones can form undisturbed. The result of this check is decisive for the proof format for the concrete load-bearing capacity.

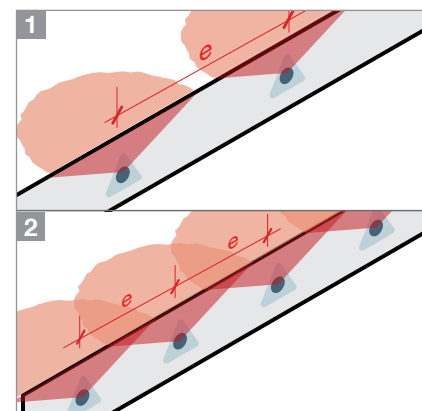

D Proof of concrete load-bearing capacity $V_{Rd,rc}$

In the case of undisturbed load distribution (fig. C-1), the slab load-bearing capacity can be determined in the direct load application area with application of the **punching shear resistance** (section 6.4 EC2). Otherwise, the **shear resistance** is decisive for the slab (section 6.2 EC2). The **punching shear** or **shear reinforcement** may also be applied. The strength classes C20/25 to C50/60 may be used for the proof of the concrete load-bearing capacity.

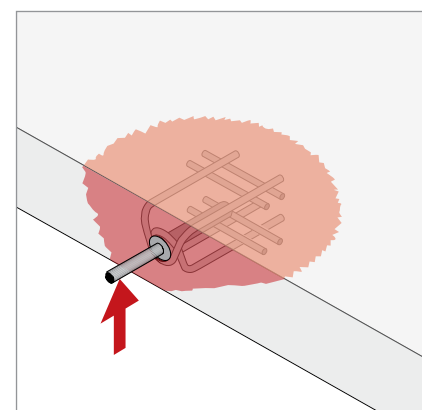

Egcodorn® product load-bearing capacity

Provided concrete failure of the connected components can be ruled out, the system load-bearing capacity of the dowel connection is given by the product load-bearing capacity of the respective Egcodorn®. A distinction must be made as to whether the displacement occurs in one direction (longitudinal or transverse) or in two directions (longitudinal and transverse). The values in the following tables are the minimum values for the product load-bearing capacities of dowel and anchor body for various joint widths and were determined on the basis of the German National Approval Z-15.7-301.

$V_{Rd,s}$ [kN] longitudinal displacement

Joint width [mm]	WN										N
	40	50	70	95	100	120	150	210	300	350	400
10	62.0	89.4	122.3	154.7	155.8	241.5	243.8	380.3	382.1	388.0	486.7
20	58.9	85.3	117.4	149.1	150.6	224.4	236.8	369.5	373.0	380.2	476.9
30	54.5	72.2	102.9	138.7	145.7	194.1	230.3	331.6	364.4	372.7	467.6
40	40.9	54.5	79.9	112.2	136.9	163.8	208.4	293.8	331.9	365.6	458.6
50	32.7	43.6	63.9	89.8	110.5	134.1	175.3	255.9	292.1	358.7	449.9
60	27.3	36.3	53.3	74.8	92.0	111.7	146.2	218.2	252.4	352.0	411.7
70	23.4	31.1	45.7	64.1	78.9	95.8	125.3	187.0	216.5	345.6	364.4
80	20.5	27.2	40.0	56.1	69.0	83.8	109.6	163.6	189.4	319.6	319.6

$V_{Rd,s}$ [kN] longitudinal and transverse displacement

Joint width [mm]	WQ										Q
	40	50	70	95	100	120	150	210	300	350	400
10	62.0	89.4	122.3	154.7	155.8	229.2	243.8	366.6	382.1	388.0	486.7
20	58.9	83.7	113.9	148.6	150.6	201.9	236.8	332.6	370.2	380.2	476.9
30	49.1	65.0	92.6	124.8	145.7	174.7	217.3	298.5	334.4	372.7	467.6
40	36.8	49.0	71.9	100.9	123.2	147.4	187.5	264.4	298.7	365.6	455.7
50	29.5	39.2	57.5	80.8	99.4	120.6	157.7	230.3	262.9	358.7	413.2
60	24.5	32.7	47.9	67.4	82.8	100.5	131.5	196.4	227.1	352.0	370.6
70	21.0	28.0	41.1	57.7	71.0	86.2	112.8	168.3	194.8	328.0	328.0
80	18.4	24.5	36.0	50.5	62.1	75.4	98.7	147.3	170.5	287.6	287.6

Standard joint width $z \leq 60$ mm, joint width $z \leq 80$ mm on enquiry
 Egcodorn® type WQ/Q transverse displacement ± 15 mm

System load-bearing capacity for slabs according to Eurocode 2

In particular in the case of thin reinforced concrete slabs, the attainment of the product load-bearing capacity of the Egcodorn cannot readily be presupposed – the slab load-bearing capacity in the load application area is often decisive here. Two execution variants for the simplification of the preliminary design of Egcodorn dowels in reinforced concrete slabs are presented below: full load-bearing capacity in case of **variant D4 with shear reinforcement** as well as adapted load-bearing capacity in case of **variant D1 without shear / punching shear reinforcement**.

Variant D4: full product load-bearing capacity – small dowel spacing – with shear reinforcement

Shear reinforcement is to be provided if the product load-bearing capacity of the Egcodorn is to be fully utilised with small dowel spacings in the reinforced concrete slabs.

For simplification of the preliminary design, the following table based on DIN EN 1992-1-1 shows the assumptions under which the product load-bearing capacity of the Egcodorn® shear force dowels can be fully activated in reinforced steel slabs according to page 16. The specified shear reinforcement (diameter and bar spacings) was selected on the basis of the respectively least favourable boundary conditions (action, slab thickness, dowel spacing, concrete). When taking into account the actual conditions, much lower degrees of shear reinforcement result in many cases.

Tip: Use our design software!

Guiding value for reinforced concrete slabs – full product load-bearing capacity, small dowel spacings, with shear reinforcement¹⁾

Standard type	WN / WQ										
	40	50	70	95	100	120	150	210	300	350	N / Q
Minimum slab thickness h_{sup} [mm]	200	200	200	200	210	230	250	280	300	350	350
Minimum dowel spacing e_{sup} ²⁾ [mm]	260	380	520	660	600	790	690	880	830	660	830
Cap stirrup diameter ³⁾ [mm]	6	6	6	6	6	8	8	10	10	10	10
Height h_k [mm]	220	240	260	290	300	320	340	380	400	410	440
Pos. 1: U-stirrup in dowel direction per side ⁴⁾	2Ø10	2Ø10	2Ø10	2Ø12	2Ø12	2Ø16	2Ø16	2Ø16	2Ø20	2Ø20	2Ø20
Pos. 2: Edge reinforcement transverse to dowel (top and bottom)	1Ø10	1Ø10	1Ø10	1Ø12	1Ø12	1Ø16	1Ø16	1Ø16	1Ø20	1Ø20	1Ø20
Shear reinforcement Pos. 3											
Stirrup diameter [mm]	10	10	10	10	10	12	12	12	16	16	16
Longitudinal spacing s_l ⁵⁾ [cm]	0.5 h										
Transverse spacing s_t [cm]	15	15	15	15	15	15	15	15	25	20	20

Assumptions: C20/25 to C50/60, B500, $c_{nom} = 30$ mm, $h \geq h_{sup}$, $e \geq e_{sup}$, $e \leq 5h$

1) The data in the table represent guiding values and must be proven in the individual case.

2) Smaller dowel spacings are possible if the shear reinforcement is adapted. Recommendation: Use the Egcodorn design software.

3) Cap stirrup only required with slab thickness $h < h_k$.

4) See p. 12 for arrangement.

5) The max. x_{sw} (see below) up to which the shear force stirrups are to be provided depends on the static system of the slab and is to be calculated for the respective boundary conditions or can be taken from the shear force proof for the slab. The maximum compression strut width in the shear force proof corresponds to the respectively selected dowel spacing.

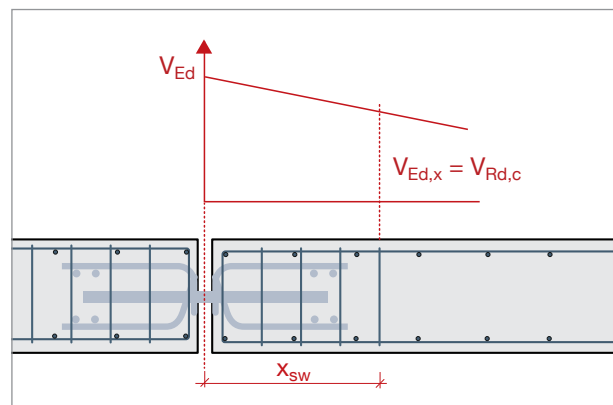
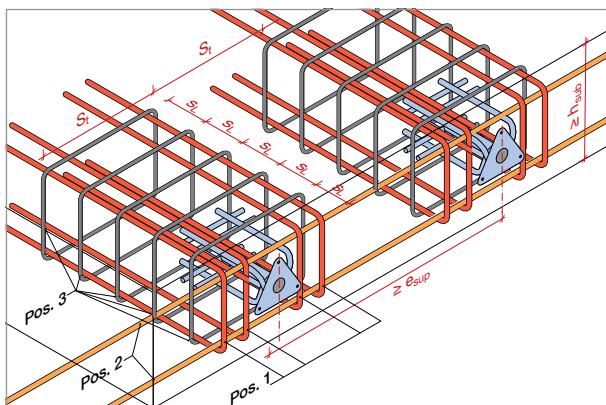

Variant D1: adapted load-bearing capacity with bigger dowel spacings – increased degree of longitudinal reinforcement – **without** shear/punching shear reinforcement

If shear/punching shear reinforcement is to be dispensed with, then larger dowel spacings and an increased degree of longitudinal reinforcement, in some cases with reduced load-bearing capacities, are mostly a requirement in reinforced concrete slabs. The values for V_{Rd} given in the following tables represent the minimum of product load-bearing capacity $V_{Rd,s}$ and concrete load-bearing capacity $V_{Rd,rc}$. The product load-bearing capacity is authoritative in the case of the **values in bold lettering**. The concrete load-bearing capacity was determined by way of example on the basis of DIN EN 1992-1-1 for some standard cases; the calculation assumptions are given in the tables. In many cases, higher load-bearing capacities can be achieved by modifying the reinforcement.

Get support for your individual design tasks from our free and intuitively usable software or our technical consultants!



Download our free design software:

www.maxfrank.com/egcodorn-software



Or contact our Customer Service!

Phone +49 9427 189-320 | customer.service@maxfrank.de

Dowel spacings/edge distances

The following tables are based on the assumption that the forces can propagate without mutual influencing of adjacent dowels; the following critical spacings apply.

It is possible to use smaller spacings than these; however, the shear force proof must then be provided instead of the punching shear proof on account of the overlapping punching cones, and different load-bearing capacities may result.

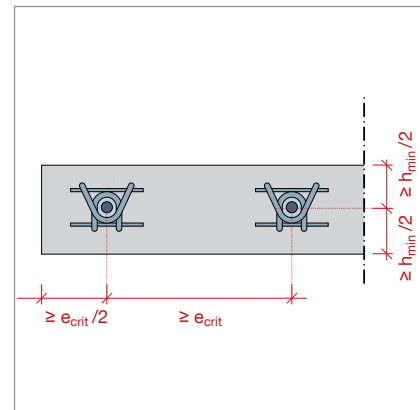

Critical dowel spacings e_{crit}

Slab thickness h [mm]	WN / WQ										N / Q 400
	40	50	70	95	100	120	150	210	300	350	
160	580	572									
180	660	652	659								
200	740	732	739	762							
220	820	812	819	842	826						
250	940	932	939	962	946	981	981				
280	1060	1052	1059	1082	1066	1101	1101	1130			
300	1140	1132	1139	1162	1146	1181	1181	1210	1210		
350	1340	1332	1339	1362	1346	1381	1381	1410	1410	1410	1410
400	1540	1532	1539	1562	1546	1581	1581	1610	1610	1610	1610
600	2340	2332	2339	2362	2346	2381	2381	2410	2410	2410	2410

The minimum lateral edge distance is $e_{crit}/2$.

In-situ reinforcement

The following reinforcement (or equivalent) is to be arranged and anchored outside of the punching shear cone when utilising the loading-bearing capacities subsequently named.

In-situ reinforcement

Standard type	WN / WQ										N / Q
	40	50	70	95	100	120	150	210	300	350	
Diameter of cap stirrup ¹⁾	6	6	6	6	6	8	8	10	10	10	10
Height h_k [mm]	220	240	260	290	300	320	340	380	400	410	440
Pos. 1: U-stirrup in dowel direction [n $\varnothing d_{sx}$] per side	3 \varnothing 10	3 \varnothing 12	3 \varnothing 14	4 \varnothing 12	5 \varnothing 16	5 \varnothing 16	5 \varnothing 16	5 \varnothing 20	5 \varnothing 20	5 \varnothing 20	5 \varnothing 20
Maximum spacing s_x [mm]	30	30	30	50	50	70	70	90	100	100	100
Pos. 2: Edge reinforcement transverse to dowel [n $\varnothing d_{sy}$], top and bottom	3 \varnothing 12	3 \varnothing 12	3 \varnothing 14	3 \varnothing 12	3 \varnothing 16	4 \varnothing 16	4 \varnothing 16	4 \varnothing 20	4 \varnothing 20	4 \varnothing 20	4 \varnothing 20

Reinforcement B500

¹⁾ Only required with slab thickness $h < h_k$, see page 12

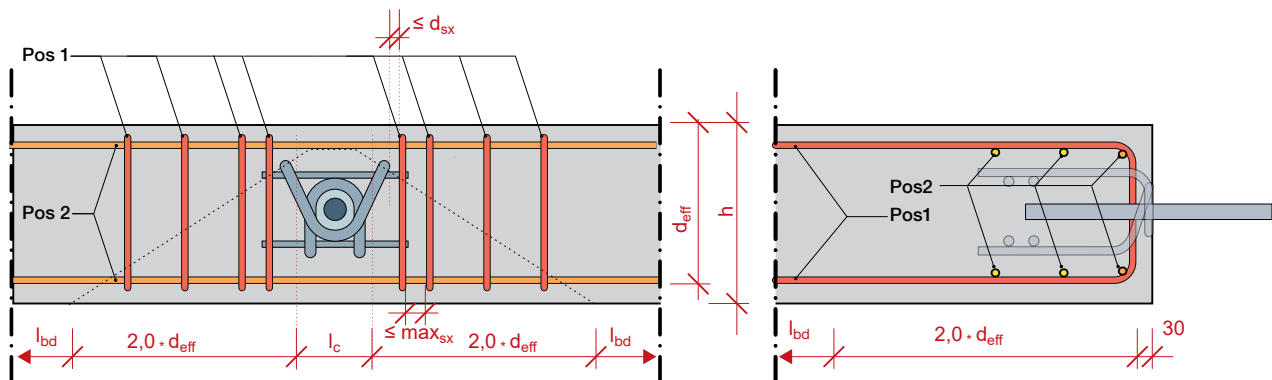

System load-bearing capacity of the dowel connection

V_{Rd} [kN] per dowel, C20/25, longitudinal displacement

Assumptions: adequate dowel spacings, see page 18

Reinforcement, see page 19

$c_{nom} = 30$ mm

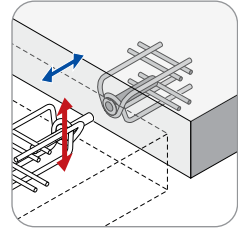

Slab thickness [mm]	Joint width [mm]	WN										N 400
		40	50	70	95	100	120	150	210	300	350	
160	20	48.2	50.2									
	30	48.2	50.2									
	40	40.9	50.2									
	50	32.7	43.6									
	60	27.3	36.3									
180	20	58.1	60.7	66.8								
	30	54.5	60.7	66.8								
	40	40.9	54.5	66.8								
	50	32.7	43.6	63.9								
	60	27.3	36.3	53.3								
200	20	58.9	71.6	78.9	76.6							
	30	54.5	71.6	78.9	76.6							
	40	40.9	54.5	78.9	76.6							
	50	32.7	43.6	63.9	76.6							
	60	27.3	36.3	53.3	74.8							
220	20	58.9	83.0	91.5	88.6	108.3						
	30	54.5	72.2	91.5	88.6	108.3						
	40	40.9	54.5	79.9	88.6	108.3						
	50	32.7	43.6	63.9	88.6	108.3						
	60	27.3	36.3	53.3	74.8	92.0						
250	20	58.9	85.3	110.4	106.3	131.1	140.0	140.0				
	30	54.5	72.2	102.9	106.3	131.1	140.0	140.0				
	40	40.9	54.5	79.9	106.3	131.1	140.0	140.0				
	50	32.7	43.6	63.9	89.8	110.5	134.1	140.0				
	60	27.3	36.3	53.3	74.8	92.0	111.7	140.0				
280	20	58.9	85.3	117.4	121.7	150.4	160.2	160.2	186.4			
	30	54.5	72.2	102.9	121.7	145.7	160.2	160.2	186.4			
	40	40.9	54.5	79.9	112.2	136.9	160.2	160.2	186.4			
	50	32.7	43.6	63.9	89.8	110.5	134.1	160.2	186.4			
	60	27.3	36.3	53.3	74.8	92.0	111.7	146.2	186.4			
300	20	58.9	85.3	117.4	132.1	150.6	173.9	173.9	202.3	202.3		
	30	54.5	72.2	102.9	132.1	145.7	173.9	173.9	202.3	202.3		
	40	40.9	54.5	79.9	112.2	136.9	163.8	173.9	202.3	202.3		
	50	32.7	43.6	63.9	89.8	110.5	134.1	173.9	202.3	202.3		
	60	27.3	36.3	53.3	74.8	92.0	111.7	146.2	202.3	202.3		
350	20	58.9	85.3	117.4	149.1	150.6	208.9	208.9	242.9	242.9	242.9	242.9
	30	54.5	72.2	102.9	138.7	145.7	194.1	208.9	242.9	242.9	242.9	242.9
	40	40.9	54.5	79.9	112.2	136.9	163.8	208.4	242.9	242.9	242.9	242.9
	50	32.7	43.6	63.9	89.8	110.5	134.1	175.3	242.9	242.9	242.9	242.9
	60	27.3	36.3	53.3	74.8	92.0	111.7	146.2	218.2	242.9	242.9	242.9
400	20	58.9	85.3	117.4	149.1	150.6	224.4	236.8	284.6	284.6	284.6	284.6
	30	54.5	72.2	102.9	138.7	145.7	194.1	230.3	284.6	284.6	284.6	284.6
	40	40.9	54.5	79.9	112.2	136.9	163.8	208.4	284.6	284.6	284.6	284.6
	50	32.7	43.6	63.9	89.8	110.5	134.1	175.3	255.9	284.6	284.6	284.6
	60	27.3	36.3	53.3	74.8	92.0	111.7	146.2	218.2	252.4	284.6	284.6
600	20	58.9	85.3	117.4	149.1	150.6	224.4	236.8	369.5	373.0	380.2	460.6
	30	54.5	72.2	102.9	138.7	145.7	194.1	230.3	331.6	364.4	372.7	460.6
	40	40.9	54.5	79.9	112.2	136.9	163.8	208.4	293.8	331.9	365.6	458.6
	50	32.7	43.6	63.9	89.8	110.5	134.1	175.3	255.9	292.1	358.7	449.9
	60	27.3	36.3	53.3	74.8	92.0	111.7	146.2	218.2	252.4	352.0	411.7

System load-bearing capacity of the dowel connection

V_{Rd} [kN] per dowel, C25/30, longitudinal displacement

Assumptions: adequate dowel spacings, see page 18

Reinforcement, see page 19

$c_{nom} = 30$ mm

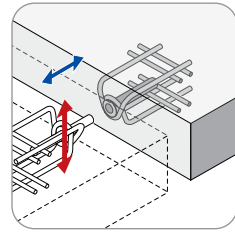

Slab thickness [mm]	Joint width [mm]	WN										N 400	
		40	50	70	95	100	120	150	210	300	350		
160	20	51.9	54.1										
	30	51.9	54.1										
	40	40.9	54.1										
	50	32.7	43.6										
	60	27.3	36.3										
180	20	58.9	65.4	71.9									
	30	54.5	65.4	71.9									
	40	40.9	54.5	71.9									
	50	32.7	43.6	63.9									
	60	27.3	36.3	53.3									
200	20	58.9	77.1	85.0	82.5								
	30	54.5	72.2	85.0	82.5								
	40	40.9	54.5	79.9	82.5								
	50	32.7	43.6	63.9	82.5								
	60	27.3	36.3	53.3	74.8								
220	20	58.9	85.3	98.6	95.4	116.7							
	30	54.5	72.2	98.6	95.4	116.7							
	40	40.9	54.5	79.9	95.4	116.7							
	50	32.7	43.6	63.9	89.8	110.5							
	60	27.3	36.3	53.3	74.8	92.0							
250	20	58.9	85.3	117.4	114.5	141.2	150.8	150.8					
	30	54.5	72.2	102.9	114.5	141.2	150.8	150.8					
	40	40.9	54.5	79.9	112.2	136.9	150.8	150.8					
	50	32.7	43.6	63.9	89.8	110.5	134.1	150.8					
	60	27.3	36.3	53.3	74.8	92.0	111.7	146.2					
280	20	58.9	85.3	117.4	131.1	150.6	172.6	172.6	200.8				
	30	54.5	72.2	102.9	131.1	145.7	172.6	172.6	200.8				
	40	40.9	54.5	79.9	112.2	136.9	163.8	172.6	200.8				
	50	32.7	43.6	63.9	89.8	110.5	134.1	172.6	200.8				
	60	27.3	36.3	53.3	74.8	92.0	111.7	146.2	200.8				
300	20	58.9	85.3	117.4	142.3	150.6	187.4	187.4	218.0	218.0			
	30	54.5	72.2	102.9	138.7	145.7	187.4	187.4	218.0	218.0			
	40	40.9	54.5	79.9	112.2	136.9	163.8	187.4	218.0	218.0			
	50	32.7	43.6	63.9	89.8	110.5	134.1	175.3	218.0	218.0			
	60	27.3	36.3	53.3	74.8	92.0	111.7	146.2	218.0	218.0			
350	20	58.9	85.3	117.4	149.1	150.6	224.4	225.0	261.7	261.7	261.7	261.7	261.7
	30	54.5	72.2	102.9	138.7	145.7	194.1	225.0	261.7	261.7	261.7	261.7	261.7
	40	40.9	54.5	79.9	112.2	136.9	163.8	208.4	261.7	261.7	261.7	261.7	261.7
	50	32.7	43.6	63.9	89.8	110.5	134.1	175.3	255.9	261.7	261.7	261.7	261.7
	60	27.3	36.3	53.3	74.8	92.0	111.7	146.2	218.2	252.4	261.7	261.7	261.7
400	20	58.9	85.3	117.4	149.1	150.6	224.4	236.8	306.5	306.5	306.5	306.5	306.5
	30	54.5	72.2	102.9	138.7	145.7	194.1	230.3	306.5	306.5	306.5	306.5	306.5
	40	40.9	54.5	79.9	112.2	136.9	163.8	208.4	293.8	306.5	306.5	306.5	306.5
	50	32.7	43.6	63.9	89.8	110.5	134.1	175.3	255.9	292.1	306.5	306.5	306.5
	60	27.3	36.3	53.3	74.8	92.0	111.7	146.2	218.2	252.4	306.5	306.5	306.5
600	20	58.9	85.3	117.4	149.1	150.6	224.4	236.8	369.5	373.0	380.2	476.9	476.9
	30	54.5	72.2	102.9	138.7	145.7	194.1	230.3	331.6	364.4	372.7	467.6	467.6
	40	40.9	54.5	79.9	112.2	136.9	163.8	208.4	293.8	331.9	365.6	458.6	458.6
	50	32.7	43.6	63.9	89.8	110.5	134.1	175.3	255.9	292.1	358.7	449.9	449.9
	60	27.3	36.3	53.3	74.8	92.0	111.7	146.2	218.2	252.4	352.0	411.7	411.7

System load-bearing capacity of the dowel connection

V_{Rd} [kN] per dowel, C30/37, longitudinal displacement

Assumptions: adequate dowel spacings, see page 18

Reinforcement, see page 19

$c_{nom} = 30$ mm

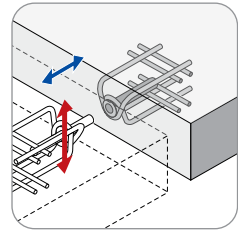

Slab thickness [mm]	Joint width [mm]	WN										N 400
		40	50	70	95	100	120	150	210	300	350	
160	20	55.2	57.4									
	30	54.5	57.4									
	40	40.9	54.5									
	50	32.7	43.6									
	60	27.3	36.3									
180	20	58.9	69.5	76.4								
	30	54.5	69.5	76.4								
	40	40.9	54.5	76.4								
	50	32.7	43.6	63.9								
	60	27.3	36.3	53.3								
200	20	58.9	82.0	90.3	87.7							
	30	54.5	72.2	90.3	87.7							
	40	40.9	54.5	79.9	87.7							
	50	32.7	43.6	63.9	87.7							
	60	27.3	36.3	53.3	74.8							
220	20	58.9	85.3	104.7	101.4	124.0						
	30	54.5	72.2	102.9	101.4	124.0						
	40	40.9	54.5	79.9	101.4	124.0						
	50	32.7	43.6	63.9	89.8	110.5						
	60	27.3	36.3	53.3	74.8	92.0						
250	20	58.9	85.3	117.4	121.7	150.1	160.2	160.2				
	30	54.5	72.2	102.9	121.7	145.7	160.2	160.2				
	40	40.9	54.5	79.9	112.2	136.9	160.2	160.2				
	50	32.7	43.6	63.9	89.8	110.5	134.1	160.2				
	60	27.3	36.3	53.3	74.8	92.0	111.7	146.2				
280	20	58.9	85.3	117.4	139.3	150.6	183.4	183.4	213.4			
	30	54.5	72.2	102.9	138.7	145.7	183.4	183.4	213.4			
	40	40.9	54.5	79.9	112.2	136.9	163.8	183.4	213.4			
	50	32.7	43.6	63.9	89.8	110.5	134.1	175.3	213.4			
	60	27.3	36.3	53.3	74.8	92.0	111.7	146.2	213.4			
300	20	58.9	85.3	117.4	149.1	150.6	199.1	199.1	231.6	231.6		
	30	54.5	72.2	102.9	138.7	145.7	194.1	199.1	231.6	231.6		
	40	40.9	54.5	79.9	112.2	136.9	163.8	199.1	231.6	231.6		
	50	32.7	43.6	63.9	89.8	110.5	134.1	175.3	231.6	231.6		
	60	27.3	36.3	53.3	74.8	92.0	111.7	146.2	218.2	231.6		
350	20	58.9	85.3	117.4	149.1	150.6	224.4	236.8	278.1	278.1	278.1	278.1
	30	54.5	72.2	102.9	138.7	145.7	194.1	230.3	278.1	278.1	278.1	278.1
	40	40.9	54.5	79.9	112.2	136.9	163.8	208.4	278.1	278.1	278.1	278.1
	50	32.7	43.6	63.9	89.8	110.5	134.1	175.3	255.9	278.1	278.1	278.1
	60	27.3	36.3	53.3	74.8	92.0	111.7	146.2	218.2	252.4	278.1	278.1
400	20	58.9	85.3	117.4	149.1	150.6	224.4	236.8	325.8	325.8	325.8	325.8
	30	54.5	72.2	102.9	138.7	145.7	194.1	230.3	325.8	325.8	325.8	325.8
	40	40.9	54.5	79.9	112.2	136.9	163.8	208.4	293.8	325.8	325.8	325.8
	50	32.7	43.6	63.9	89.8	110.5	134.1	175.3	255.9	292.1	325.8	325.8
	60	27.3	36.3	53.3	74.8	92.0	111.7	146.2	218.2	252.4	325.8	325.8
600	20	58.9	85.3	117.4	149.1	150.6	224.4	236.8	369.5	373.0	380.2	476.9
	30	54.5	72.2	102.9	138.7	145.7	194.1	230.3	331.6	364.4	372.7	467.6
	40	40.9	54.5	79.9	112.2	136.9	163.8	208.4	293.8	331.9	365.6	458.6
	50	32.7	43.6	63.9	89.8	110.5	134.1	175.3	255.9	292.1	358.7	449.9
	60	27.3	36.3	53.3	74.8	92.0	111.7	146.2	218.2	252.4	352.0	411.7

System load-bearing capacity of the dowel connection

V_{Rd} [kN] per dowel, C20/25, longitudinal and transverse displacement

Assumptions: adequate dowel spacings, see page 18

Reinforcement, see page 19

$c_{nom} = 30$ mm

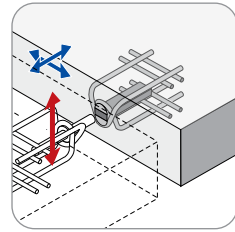

Slab thickness [mm]	Joint width [mm]	WQ										Q	
		40	50	70	95	100	120	150	210	300	350		400
160	20	48.2	50.2										
	30	48.2	50.2										
	40	36.8	49.0										
	50	29.5	39.2										
	60	24.5	32.7										
180	20	58.1	60.7	66.8									
	30	49.1	60.7	66.8									
	40	36.8	49.0	66.8									
	50	29.5	39.2	57.5									
	60	24.5	32.7	47.9									
200	20	58.9	71.6	78.9	76.6								
	30	49.1	65.0	78.9	76.6								
	40	36.8	49.0	71.9	76.6								
	50	29.5	39.2	57.5	76.6								
	60	24.5	32.7	47.9	67.4								
220	20	58.9	83.0	91.5	88.6	108.3							
	30	49.1	65.0	91.5	88.6	108.3							
	40	36.8	49.0	71.9	88.6	108.3							
	50	29.5	39.2	57.5	80.8	99.4							
	60	24.5	32.7	47.9	67.4	82.8							
250	20	58.9	83.7	110.4	106.3	131.1	140.0	140.0					
	30	49.1	65.0	92.6	106.3	131.1	140.0	140.0					
	40	36.8	49.0	71.9	100.9	123.2	140.0	140.0					
	50	29.5	39.2	57.5	80.8	99.4	120.6	140.0					
	60	24.5	32.7	47.9	67.4	82.8	100.5	131.5					
280	20	58.9	83.7	113.9	121.7	150.4	160.2	160.2	186.4				
	30	49.1	65.0	92.6	121.7	145.7	160.2	160.2	186.4				
	40	36.8	49.0	71.9	100.9	123.2	147.4	160.2	186.4				
	50	29.5	39.2	57.5	80.8	99.4	120.6	157.7	186.4				
	60	24.5	32.7	47.9	67.4	82.8	100.5	131.5	186.4				
300	20	58.9	83.7	113.9	132.1	150.6	173.9	173.9	202.3	202.3			
	30	49.1	65.0	92.6	124.8	145.7	173.9	173.9	202.3	202.3			
	40	36.8	49.0	71.9	100.9	123.2	147.4	173.9	202.3	202.3			
	50	29.5	39.2	57.5	80.8	99.4	120.6	157.7	202.3	202.3			
	60	24.5	32.7	47.9	67.4	82.8	100.5	131.5	196.4	202.3			
350	20	58.9	83.7	113.9	148.6	150.6	201.9	208.9	242.9	242.9	242.9	242.9	
	30	49.1	65.0	92.6	124.8	145.7	174.7	208.9	242.9	242.9	242.9	242.9	
	40	36.8	49.0	71.9	100.9	123.2	147.4	187.5	242.9	242.9	242.9	242.9	
	50	29.5	39.2	57.5	80.8	99.4	120.6	157.7	230.3	242.9	242.9	242.9	
	60	24.5	32.7	47.9	67.4	82.8	100.5	131.5	196.4	227.1	242.9	242.9	
400	20	58.9	83.7	113.9	148.6	150.6	201.9	236.8	284.6	284.6	284.6	284.6	
	30	49.1	65.0	92.6	124.8	145.7	174.7	217.3	284.6	284.6	284.6	284.6	
	40	36.8	49.0	71.9	100.9	123.2	147.4	187.5	264.4	284.6	284.6	284.6	
	50	29.5	39.2	57.5	80.8	99.4	120.6	157.7	230.3	262.9	284.6	284.6	
	60	24.5	32.7	47.9	67.4	82.8	100.5	131.5	196.4	227.1	284.6	284.6	
600	20	58.9	83.7	113.9	148.6	150.6	201.9	236.8	332.6	370.2	380.2	460.6	
	30	49.1	65.0	92.6	124.8	145.7	174.7	217.3	298.5	334.4	372.7	460.6	
	40	36.8	49.0	71.9	100.9	123.2	147.4	187.5	264.4	298.7	365.6	455.7	
	50	29.5	39.2	57.5	80.8	99.4	120.6	157.7	230.3	262.9	358.7	413.2	
	60	24.5	32.7	47.9	67.4	82.8	100.5	131.5	196.4	227.1	352.0	370.6	

System load-bearing capacity of the dowel connection

V_{Rd} [kN] per dowel, C25/30, longitudinal and transverse displacement

Assumptions: adequate dowel spacings, see page 18

Reinforcement, see page 19

$c_{nom} = 30$ mm

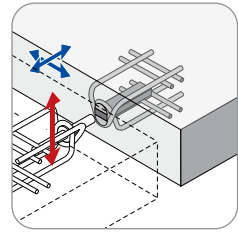

Slab thickness [mm]	Joint width [mm]	WQ										Q	
		40	50	70	95	100	120	150	210	300	350		400
160	20	51.9	54.1										
	30	49.1	54.1										
	40	36.8	49.0										
	50	29.5	39.2										
	60	24.5	32.7										
180	20	58.9	65.4	71.9									
	30	49.1	65.0	71.9									
	40	36.8	49.0	71.9									
	50	29.5	39.2	57.5									
	60	24.5	32.7	47.9									
200	20	58.9	77.1	85.0	82.5								
	30	49.1	65.0	85.0	82.5								
	40	36.8	49.0	71.9	82.5								
	50	29.5	39.2	57.5	80.8								
	60	24.5	32.7	47.9	67.4								
220	20	58.9	83.7	98.6	95.4	116.7							
	30	49.1	65.0	92.6	95.4	116.7							
	40	36.8	49.0	71.9	95.4	116.7							
	50	29.5	39.2	57.5	80.8	99.4							
	60	24.5	32.7	47.9	67.4	82.8							
250	20	58.9	83.7	113.9	114.5	141.2	150.8	150.8					
	30	49.1	65.0	92.6	114.5	141.2	150.8	150.8					
	40	36.8	49.0	71.9	100.9	123.2	147.4	150.8					
	50	29.5	39.2	57.5	80.8	99.4	120.6	150.8					
	60	24.5	32.7	47.9	67.4	82.8	100.5	131.5					
280	20	58.9	83.7	113.9	131.1	150.6	172.6	172.6	200.8				
	30	49.1	65.0	92.6	124.8	145.7	172.6	172.6	200.8				
	40	36.8	49.0	71.9	100.9	123.2	147.4	172.6	200.8				
	50	29.5	39.2	57.5	80.8	99.4	120.6	157.7	200.8				
	60	24.5	32.7	47.9	67.4	82.8	100.5	131.5	196.4				
300	20	58.9	83.7	113.9	142.3	150.6	187.4	187.4	218.0	218.0			
	30	49.1	65.0	92.6	124.8	145.7	174.7	187.4	218.0	218.0			
	40	36.8	49.0	71.9	100.9	123.2	147.4	187.4	218.0	218.0			
	50	29.5	39.2	57.5	80.8	99.4	120.6	157.7	218.0	218.0			
	60	24.5	32.7	47.9	67.4	82.8	100.5	131.5	196.4	218.0			
350	20	58.9	83.7	113.9	148.6	150.6	201.9	225.0	261.7	261.7	261.7	261.7	261.7
	30	49.1	65.0	92.6	124.8	145.7	174.7	217.3	261.7	261.7	261.7	261.7	261.7
	40	36.8	49.0	71.9	100.9	123.2	147.4	187.5	261.7	261.7	261.7	261.7	261.7
	50	29.5	39.2	57.5	80.8	99.4	120.6	157.7	230.3	261.7	261.7	261.7	261.7
	60	24.5	32.7	47.9	67.4	82.8	100.5	131.5	196.4	227.1	261.7	261.7	261.7
400	20	58.9	83.7	113.9	148.6	150.6	201.9	236.8	306.5	306.5	306.5	306.5	306.5
	30	49.1	65.0	92.6	124.8	145.7	174.7	217.3	298.5	306.5	306.5	306.5	306.5
	40	36.8	49.0	71.9	100.9	123.2	147.4	187.5	264.4	298.7	306.5	306.5	306.5
	50	29.5	39.2	57.5	80.8	99.4	120.6	157.7	230.3	262.9	306.5	306.5	306.5
	60	24.5	32.7	47.9	67.4	82.8	100.5	131.5	196.4	227.1	306.5	306.5	306.5
600	20	58.9	83.7	113.9	148.6	150.6	201.9	236.8	332.6	370.2	380.2	476.9	
	30	49.1	65.0	92.6	124.8	145.7	174.7	217.3	298.5	334.4	372.7	399.5	
	40	36.8	49.0	71.9	100.9	123.2	147.4	187.5	264.4	298.7	365.6	399.5	
	50	29.5	39.2	57.5	80.8	99.4	120.6	157.7	230.3	262.9	358.7	399.5	
	60	24.5	32.7	47.9	67.4	82.8	100.5	131.5	196.4	227.1	352.0	370.6	

System load-bearing capacity of the dowel connection

V_{Rd} [kN] per dowel, C30/37, longitudinal and transverse displacement

Assumptions: adequate dowel spacings, see page 18

Reinforcement, see page 19

$c_{nom} = 30$ mm

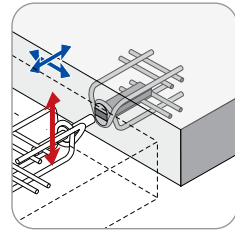

Slab thickness [mm]	Joint width [mm]	WQ										Q	
		40	50	70	95	100	120	150	210	300	350		400
160	20	55.2	57.4										
	30	49.1	57.4										
	40	36.8	49.0										
	50	29.5	39.2										
	60	24.5	32.7										
180	20	58.9	69.5	76.4									
	30	49.1	65.0	76.4									
	40	36.8	49.0	71.9									
	50	29.5	39.2	57.5									
	60	24.5	32.7	47.9									
200	20	58.9	82.0	90.3	87.7								
	30	49.1	65.0	90.3	87.7								
	40	36.8	49.0	71.9	87.7								
	50	29.5	39.2	57.5	80.8								
	60	24.5	32.7	47.9	67.4								
220	20	58.9	83.7	104.7	101.4	124.0							
	30	49.1	65.0	92.6	101.4	124.0							
	40	36.8	49.0	71.9	100.9	123.2							
	50	29.5	39.2	57.5	80.8	99.4							
	60	24.5	32.7	47.9	67.4	82.8							
250	20	58.9	83.7	113.9	121.7	150.1	160.2	160.2					
	30	49.1	65.0	92.6	121.7	145.7	160.2	160.2					
	40	36.8	49.0	71.9	100.9	123.2	147.4	160.2					
	50	29.5	39.2	57.5	80.8	99.4	120.6	157.7					
	60	24.5	32.7	47.9	67.4	82.8	100.5	131.5					
280	20	58.9	83.7	113.9	139.3	150.6	183.4	183.4	213.4				
	30	49.1	65.0	92.6	124.8	145.7	174.7	183.4	213.4				
	40	36.8	49.0	71.9	100.9	123.2	147.4	183.4	213.4				
	50	29.5	39.2	57.5	80.8	99.4	120.6	157.7	213.4				
	60	24.5	32.7	47.9	67.4	82.8	100.5	131.5	196.4				
300	20	58.9	83.7	113.9	148.6	150.6	199.1	199.1	231.6	231.6			
	30	49.1	65.0	92.6	124.8	145.7	174.7	199.1	231.6	231.6			
	40	36.8	49.0	71.9	100.9	123.2	147.4	187.5	231.6	231.6			
	50	29.5	39.2	57.5	80.8	99.4	120.6	157.7	230.3	231.6			
	60	24.5	32.7	47.9	67.4	82.8	100.5	131.5	196.4	227.1			
350	20	58.9	83.7	113.9	148.6	150.6	201.9	236.8	278.1	278.1	278.1	278.1	
	30	49.1	65.0	92.6	124.8	145.7	174.7	217.3	278.1	278.1	278.1	278.1	
	40	36.8	49.0	71.9	100.9	123.2	147.4	187.5	264.4	278.1	278.1	278.1	
	50	29.5	39.2	57.5	80.8	99.4	120.6	157.7	230.3	262.9	278.1	278.1	
	60	24.5	32.7	47.9	67.4	82.8	100.5	131.5	196.4	227.1	278.1	278.1	
400	20	58.9	83.7	113.9	148.6	150.6	201.9	236.8	325.8	325.8	325.8	325.8	
	30	49.1	65.0	92.6	124.8	145.7	174.7	217.3	298.5	325.8	325.8	325.8	
	40	36.8	49.0	71.9	100.9	123.2	147.4	187.5	264.4	298.7	325.8	325.8	
	50	29.5	39.2	57.5	80.8	99.4	120.6	157.7	230.3	262.9	325.8	325.8	
	60	24.5	32.7	47.9	67.4	82.8	100.5	131.5	196.4	227.1	325.8	325.8	
600	20	58.9	83.7	113.9	148.6	150.6	201.9	236.8	332.6	370.2	380.2	476.9	
	30	49.1	65.0	92.6	124.8	145.7	174.7	217.3	298.5	334.4	372.7	467.6	
	40	36.8	49.0	71.9	100.9	123.2	147.4	187.5	264.4	298.7	365.6	455.7	
	50	29.5	39.2	57.5	80.8	99.4	120.6	157.7	230.3	262.9	358.7	413.2	
	60	24.5	32.7	47.9	67.4	82.8	100.5	131.5	196.4	227.1	352.0	370.6	

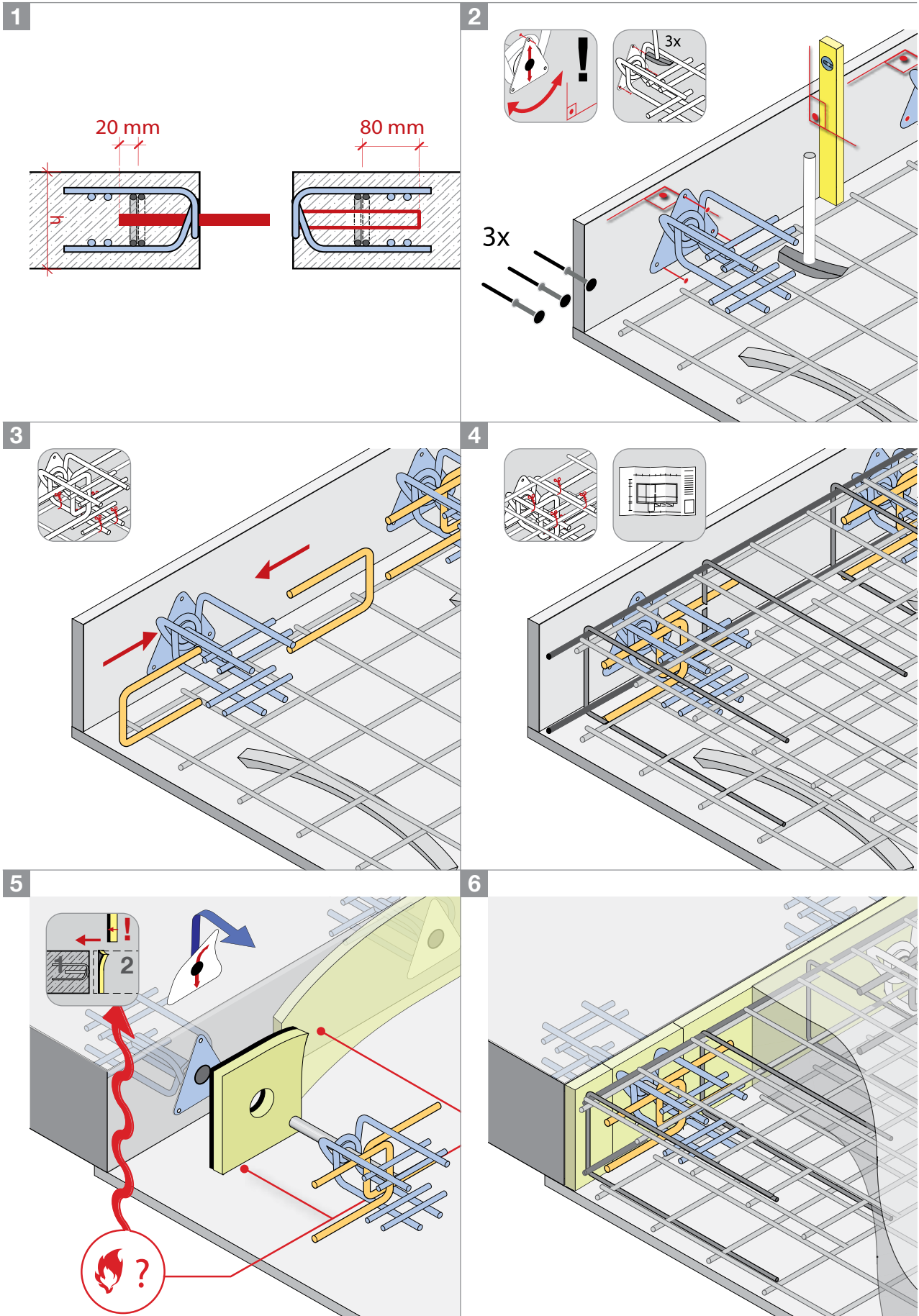

These application guidelines can only be regarded as a recommendation. They are no substitute for the specialised knowledge required for the installation. The instructions are always kept at the latest state of the art and are continually updated. Technical amendments are therefore expressly reserved - including without prior information to the customer. The most recent version can be found on our website at: www.maxfrank.com. Our general terms of sale are also applicable.

Great Eastern Quay

London, United Kingdom

Gallions Quarter and Great Eastern Quays are both located in the Royal Albert Basin area of the Royal Albert Docks in London. Together, both sites will deliver new homes into the area, which is being marketed as Royal Albert Wharf.

Surrounding nearly 250 acres of water, the Royal Docks are the largest enclosed docks in the world. More than 9,000 new homes will be constructed in the area by 2027. This development comprises three different sites into a single scheme with integrated masterplanning from NHG and a coherent design approach.

MAX FRANK supplied the Egcodorn® shear force dowels type WQ and WN 210 for this project. Each dowel was designed to transfer 370 kN at a joint opening of 20 mm.

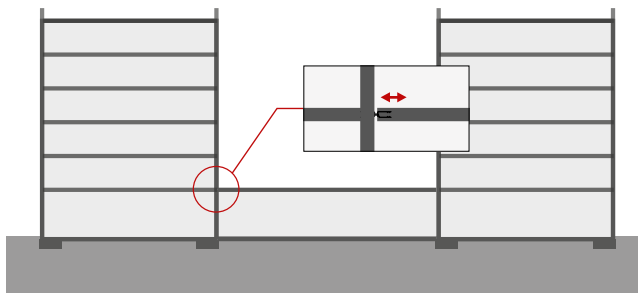

Project dates

Type of building	Habitation
Clients and Developers	Notting Hill Genesis (NHG)
Architect	Maccreanor Lavington Architects and Fielden Clegg Bradley Studios
Building contractor	Galliford Try Plc and Telford Homes Plc



BUILDING
COMMON GROUND

Egcodorn®

SWN/SWQ shear force dowel
for wall application



Egcodorn® SWN/SWQ shear force dowel

for wall application

The Egcodorn® SWN/SWQ forms a combination of a dowel with an anchor body and a sleeve set in concrete without an anchor body.

This changes the static conditions compared to the standard application Egcodorn® WN/WQ, N/Q, which results in different load capacities (see product load-bearing capacity on page 30).

On the wall side, these load-bearing capacities are achieved if the reinforcement specifications according to table in-situ reinforcement – wall on page 31 are observed.

On the slab side, an Egcodorn® with anchor body is installed. Therefore, the reinforcement specifications according to table in-situ reinforcement – slab on page 30 are observed.

★ Advantages

- Shorter installation dimension in the wall compared to the type with anchor body
- Due to the static and geometric conditions of walls, the anchor body can be dispensed with
- Also suitable for retrofitting (drilling and gluing), the required minimum reinforcement or equivalent must be verified
- The longitudinally displaceable Egcodorn® SWN allows displacements in the direction of the longitudinal axis of the dowel
- The transversely displaceable Egcodorn® SWQ allows displacements in both directions

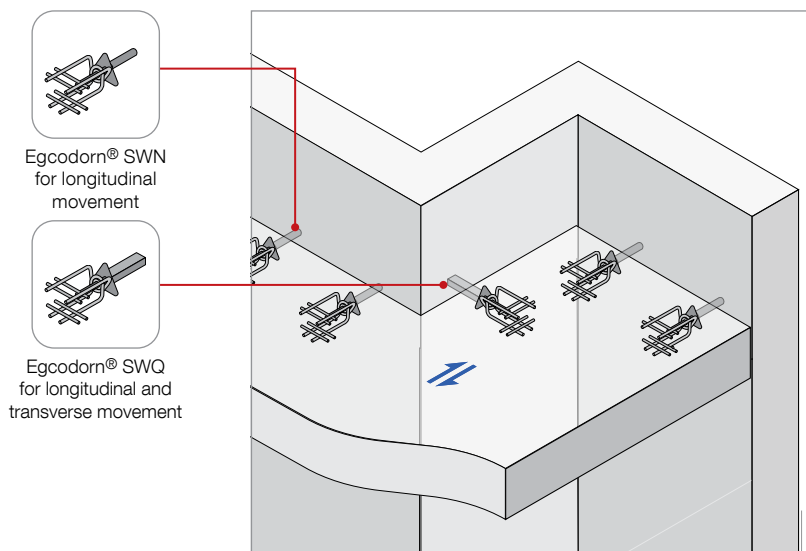

Egcodorn® product load-bearing capacity

Provided concrete failure of the connected components can be ruled out, the system load-bearing capacity of the dowel connection is given by the product load-bearing capacity of the respective Egcodorn®. A distinction must be made as to whether the displacement occurs in one direction (longitudinal) or in two directions (longitudinal and transverse). The values in the following tables are the minimum values for the product load-bearing capacities of dowel and anchor body for various joint widths and were determined on the basis of the German National Approval Z-15.7-301.

$V_{Rd,s}$ [kN] longitudinal displacement

Joint width [mm]	SWN									
	40	50	70	95	100	120	150	210	300	350
10	41.2	51.4	68.8	86.3	98.3	111.1	131.8	170.2	186.9	261.6
20	32.9	41.6	56.6	74.2	87.4	101.7	125.4	167.5	184.1	258.3
30	27.4	34.9	48.1	63.7	75.4	88.3	109.7	151.0	169.5	255.0
40	23.5	30.1	41.8	55.8	66.4	78.0	97.5	135.4	152.5	232.0
50	20.5	26.4	37.0	49.6	59.3	69.9	87.7	122.7	138.5	212.7
60	18.2	23.6	33.1	44.7	53.5	63.3	79.8	112.2	126.9	196.4
70	16.4	21.3	30.0	40.6	48.8	57.8	73.1	103.3	117.1	182.4
80	14.9	19.4	27.4	37.3	44.8	53.2	67.5	95.8	108.7	170.2

$V_{Rd,s}$ [kN] longitudinal and transverse displacement

Joint width [mm]	SWQ									
	40	50	70	95	100	120	150	210	300	350
10	37.1	46.2	61.9	80.0	93.4	107.9	131.7	170.2	186.9	261.6
20	29.6	37.4	51.0	66.8	78.6	91.5	112.8	153.6	171.8	255.1
30	24.7	31.4	43.3	57.3	67.9	79.5	98.7	135.9	152.6	229.7
40	21.1	27.1	37.6	50.2	59.7	70.2	87.7	121.8	137.2	208.8
50	18.5	23.8	33.3	44.7	53.3	62.9	79.0	110.4	124.7	191.4
60	16.4	21.2	29.8	40.2	48.2	57.0	71.8	101.0	114.2	176.7
70	14.8	19.1	27.0	36.6	43.9	52.0	65.8	93.0	105.4	164.1
80	13.4	17.4	24.7	33.5	40.3	47.9	60.7	86.2	97.8	153.2

Standard joint width $z \leq 60$ mm, joint width $z \leq 80$ mm on enquiry
Egcodorn® type WQ/Q transverse displacement ± 15 mm

In-situ reinforcement – slab

The following reinforcement (or equivalent) is to be arranged and anchored outside of the punching shear cone when utilising the loading-bearing capacities subsequently named.

Standard type	WN / WQ									
	40	50	70	95	100	120	150	210	300	350
Diameter of cap stirrup ¹⁾	6	6	6	6	6	8	8	10	10	10
Height h_k [mm]	220	240	260	290	300	320	340	380	400	410

Pos. 1: U-stirrup in dowel direction [n \varnothing d_{sx}] per side	2 \varnothing 10	2 \varnothing 10	2 \varnothing 10	2 \varnothing 12	2 \varnothing 12	2 \varnothing 14	2 \varnothing 14	2 \varnothing 16	2 \varnothing 20	3 \varnothing 20
Maximum spacing s_x [mm]	30	30	30	50	50	70	70	90	100	100
Pos. 2: Edge reinforcement transverse to dowel [n \varnothing d_{sy}], top and bottom	1 \varnothing 10	1 \varnothing 10	1 \varnothing 10	1 \varnothing 12	1 \varnothing 12	1 \varnothing 14	2 \varnothing 14	2 \varnothing 16	2 \varnothing 20	2 \varnothing 20

Reinforcement B500

¹⁾ Only required with slab thickness $h < h_k$, see page 12

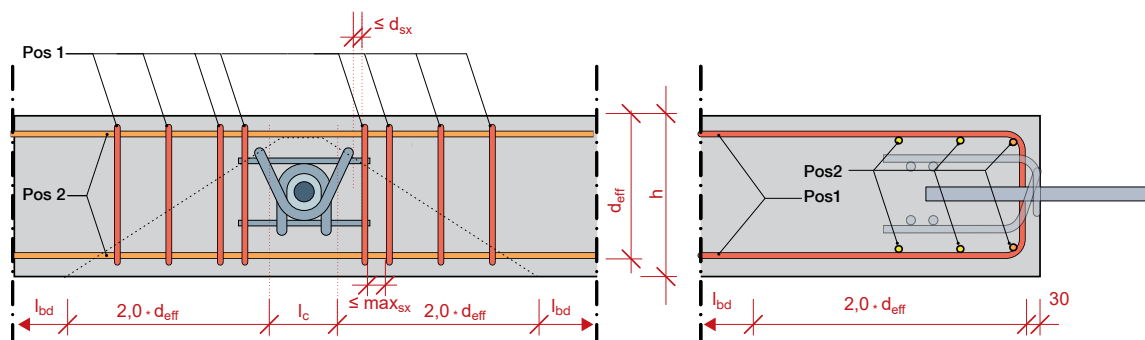

In-situ reinforcement – wall

The following reinforcement (or equivalent) is to be arranged and anchored when utilising the loading-bearing capacities subsequently named.

Standard type	SWN / SWQ									
	40	50	70	95	100	120	150	210	300	350
Pos. 1: stirrup in vertical direction [n \varnothing d_{sx}] per side	2 \varnothing 10	2 \varnothing 12	2 \varnothing 12	2 \varnothing 12	2 \varnothing 12	2 \varnothing 14	2 \varnothing 14	2 \varnothing 16	2 \varnothing 20	2 \varnothing 20
Pos. 2: stirrup in horizontal direction [n \varnothing d_{sy}], top and bottom	1 \varnothing 12	1 \varnothing 12	1 \varnothing 12	1 \varnothing 12	1 \varnothing 14	1 \varnothing 14	1 \varnothing 14	1 \varnothing 16	1 \varnothing 20	1 \varnothing 20

Layout of a constructive stirrup reinforcement in the wall (without anchor element)

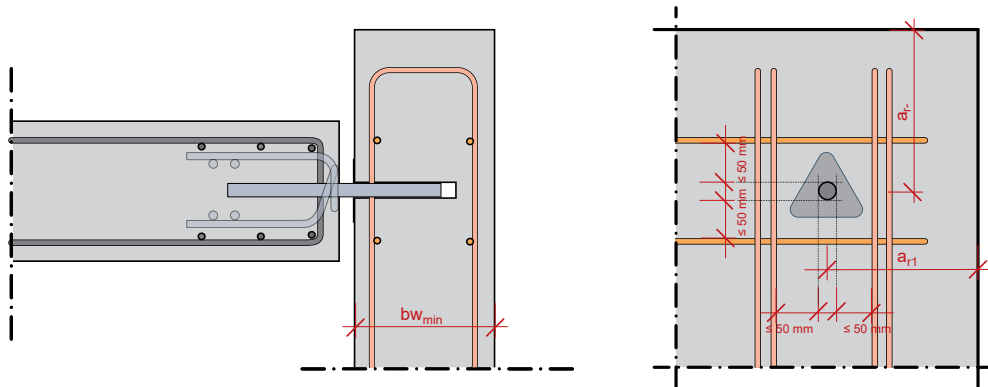

Standard type	SWN / SWQ									
	40	50	70	95	100	120	150	210	300	350
dimensions										
minimum wall thickness $b_{w,min}$ [mm]	185	195	210	225	235	245	260	285	335	335
minimum edge distance a_{r1} [mm]	450	500	550	600	650	700	750	850	900	900
minimum edge distance a_{r-} [mm]	195	200	205	210	215	220	225	235	300	300

Drilling and gluing into the wall at a later date is generally possible. However, the reinforcement specified above (or equivalent) must also be verified in this case. Alternatively, the structural engineer must prove the load transfer into the wall.

System load-bearing capacity of the dowel connection

V_{Rd} [kN] per dowel, C30/37, longitudinal displacement

Assumptions: adequate dowel spacings, see page 18

Reinforcement, see page 30 and 31

$c_{nom} = 30$ mm

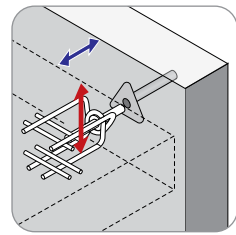

Slab thickness [mm]	Joint width [mm]	SWN									
		40	50	70	95	100	120	150	210	300	350
160	20	32.9	40.4								
	30	27.4	34.9								
	40	23.5	30.1								
	50	20.5	26.4								
	60	18.2	23.6								
180	20	32.9	41.6	49.2							
	30	27.4	34.9	48.1							
	40	23.5	30.1	41.8							
	50	20.5	26.4	37.0							
	60	18.2	23.6	33.1							
200	20	32.9	41.6	56.6	65.0						
	30	27.4	34.9	48.1	63.7						
	40	23.5	30.1	41.8	55.8						
	50	20.5	26.4	37.0	49.6						
	60	18.2	23.6	33.1	44.7						
220	20	32.9	41.6	56.6	74.2	75.2					
	30	27.4	34.9	48.1	63.7	75.2					
	40	23.5	30.1	41.8	55.8	66.4					
	50	20.5	26.4	37.0	49.6	59.3					
	60	18.2	23.6	33.1	44.7	53.5					
250	20	32.9	41.6	56.6	74.2	87.4	100.8	113.2			
	30	27.4	34.9	48.1	63.7	75.4	88.3	109.7			
	40	23.5	30.1	41.8	55.8	66.4	78.0	97.5			
	50	20.5	26.4	37.0	49.6	59.3	69.9	87.7			
	60	18.2	23.6	33.1	44.7	53.5	63.3	79.8			
280	20	32.9	41.6	56.6	74.2	87.4	101.7	125.4	143.0		
	30	27.4	34.9	48.1	63.7	75.4	88.3	109.7	143.0		
	40	23.5	30.1	41.8	55.8	66.4	78.0	97.5	135.4		
	50	20.5	26.4	37.0	49.6	59.3	69.9	87.7	122.7		
	60	18.2	23.6	33.1	44.7	53.5	63.3	79.8	112.2		
300	20	32.9	41.6	56.6	74.2	87.4	101.7	125.4	155.1	177.1	
	30	27.4	34.9	48.1	63.7	75.4	88.3	109.7	151.0	169.5	
	40	23.5	30.1	41.8	55.8	66.4	78.0	97.5	135.4	152.5	
	50	20.5	26.4	37.0	49.6	59.3	69.9	87.7	122.7	138.5	
	60	18.2	23.6	33.1	44.7	53.5	63.3	79.8	112.2	126.9	
350	20	32.9	41.6	56.6	74.2	87.4	101.7	125.4	167.5	184.1	227.5
	30	27.4	34.9	48.1	63.7	75.4	88.3	109.7	151.0	169.5	227.5
	40	23.5	30.1	41.8	55.8	66.4	78.0	97.5	135.4	152.5	227.5
	50	20.5	26.4	37.0	49.6	59.3	69.9	87.7	122.7	138.5	212.7
	60	18.2	23.6	33.1	44.7	53.5	63.3	79.8	112.2	126.9	196.4
400	20	32.9	41.6	56.6	74.2	87.4	101.7	125.4	167.5	184.1	258.3
	30	27.4	34.9	48.1	63.7	75.4	88.3	109.7	151.0	169.5	255.0
	40	23.5	30.1	41.8	55.8	66.4	78.0	97.5	135.4	152.5	232.0
	50	20.5	26.4	37.0	49.6	59.3	69.9	87.7	122.7	138.5	212.7
	60	18.2	23.6	33.1	44.7	53.5	63.3	79.8	112.2	126.9	196.4
600	20	32.9	41.6	56.6	74.2	87.4	101.7	125.4	167.5	184.1	258.3
	30	27.4	34.9	48.1	63.7	75.4	88.3	109.7	151.0	169.5	255.0
	40	23.5	30.1	41.8	55.8	66.4	78.0	97.5	135.4	152.5	232.0
	50	20.5	26.4	37.0	49.6	59.3	69.9	87.7	122.7	138.5	212.7
	60	18.2	23.6	33.1	44.7	53.5	63.3	79.8	112.2	126.9	196.4

System load-bearing capacity of the dowel connection

V_{Rd} [kN] per dowel, C30/37, longitudinal and transverse displacement

Assumptions: adequate dowel spacings, see page 18

Reinforcement, see page 30 and 31

$c_{nom} = 30$ mm

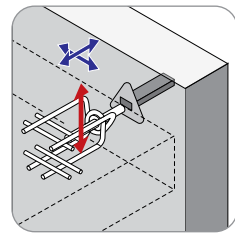

Slab thickness [mm]	Joint width [mm]	SWQ									
		40	50	70	95	100	120	150	210	300	350
160	20	29.6	37.4								
	30	24.7	31.4								
	40	21.1	27.1								
	50	18.5	23.8								
	60	16.4	21.2								
180	20	29.6	37.4	49.2							
	30	24.7	31.4	43.3							
	40	21.1	27.1	37.6							
	50	18.5	23.8	33.3							
	60	16.4	21.2	29.8							
200	20	29.6	37.4	51.0	65.0						
	30	24.7	31.4	43.3	57.3						
	40	21.1	27.1	37.6	50.2						
	50	18.5	23.8	33.3	44.7						
	60	16.4	21.2	29.8	40.2						
220	20	29.6	37.4	51.0	66.8	75.2					
	30	24.7	31.4	43.3	57.3	67.9					
	40	21.1	27.1	37.6	50.2	59.7					
	50	18.5	23.8	33.3	44.7	53.3					
	60	16.4	21.2	29.8	40.2	48.2					
250	20	29.6	37.4	51.0	66.8	78.6	91.5	112.8			
	30	24.7	31.4	43.3	57.3	67.9	79.5	98.7			
	40	21.1	27.1	37.6	50.2	59.7	70.2	87.7			
	50	18.5	23.8	33.3	44.7	53.3	62.9	79.0			
	60	16.4	21.2	29.8	40.2	48.2	57.0	71.8			
280	20	29.6	37.4	51.0	66.8	78.6	91.5	112.8	143.0		
	30	24.7	31.4	43.3	57.3	67.9	79.5	98.7	135.9		
	40	21.1	27.1	37.6	50.2	59.7	70.2	87.7	121.8		
	50	18.5	23.8	33.3	44.7	53.3	62.9	79.0	110.4		
	60	16.4	21.2	29.8	40.2	48.2	57.0	71.8	101.0		
300	20	29.6	37.4	51.0	66.8	78.6	91.5	112.8	153.6	171.8	
	30	24.7	31.4	43.3	57.3	67.9	79.5	98.7	135.9	152.6	
	40	21.1	27.1	37.6	50.2	59.7	70.2	87.7	121.8	137.2	
	50	18.5	23.8	33.3	44.7	53.3	62.9	79.0	110.4	124.7	
	60	16.4	21.2	29.8	40.2	48.2	57.0	71.8	101.0	114.2	
350	20	29.6	37.4	51.0	66.8	78.6	91.5	112.8	153.6	171.8	227.5
	30	24.7	31.4	43.3	57.3	67.9	79.5	98.7	135.9	152.6	227.5
	40	21.1	27.1	37.6	50.2	59.7	70.2	87.7	121.8	137.2	208.8
	50	18.5	23.8	33.3	44.7	53.3	62.9	79.0	110.4	124.7	191.4
	60	16.4	21.2	29.8	40.2	48.2	57.0	71.8	101.0	114.2	176.7
400	20	29.6	37.4	51.0	66.8	78.6	91.5	112.8	153.6	171.8	255.1
	30	24.7	31.4	43.3	57.3	67.9	79.5	98.7	135.9	152.6	229.7
	40	21.1	27.1	37.6	50.2	59.7	70.2	87.7	121.8	137.2	208.8
	50	18.5	23.8	33.3	44.7	53.3	62.9	79.0	110.4	124.7	191.4
	60	16.4	21.2	29.8	40.2	48.2	57.0	71.8	101.0	114.2	176.7
600	20	29.6	37.4	51.0	66.8	78.6	91.5	112.8	153.6	171.8	255.1
	30	24.7	31.4	43.3	57.3	67.9	79.5	98.7	135.9	152.6	229.7
	40	21.1	27.1	37.6	50.2	59.7	70.2	87.7	121.8	137.2	208.8
	50	18.5	23.8	33.3	44.7	53.3	62.9	79.0	110.4	124.7	191.4
	60	16.4	21.2	29.8	40.2	48.2	57.0	71.8	101.0	114.2	176.7

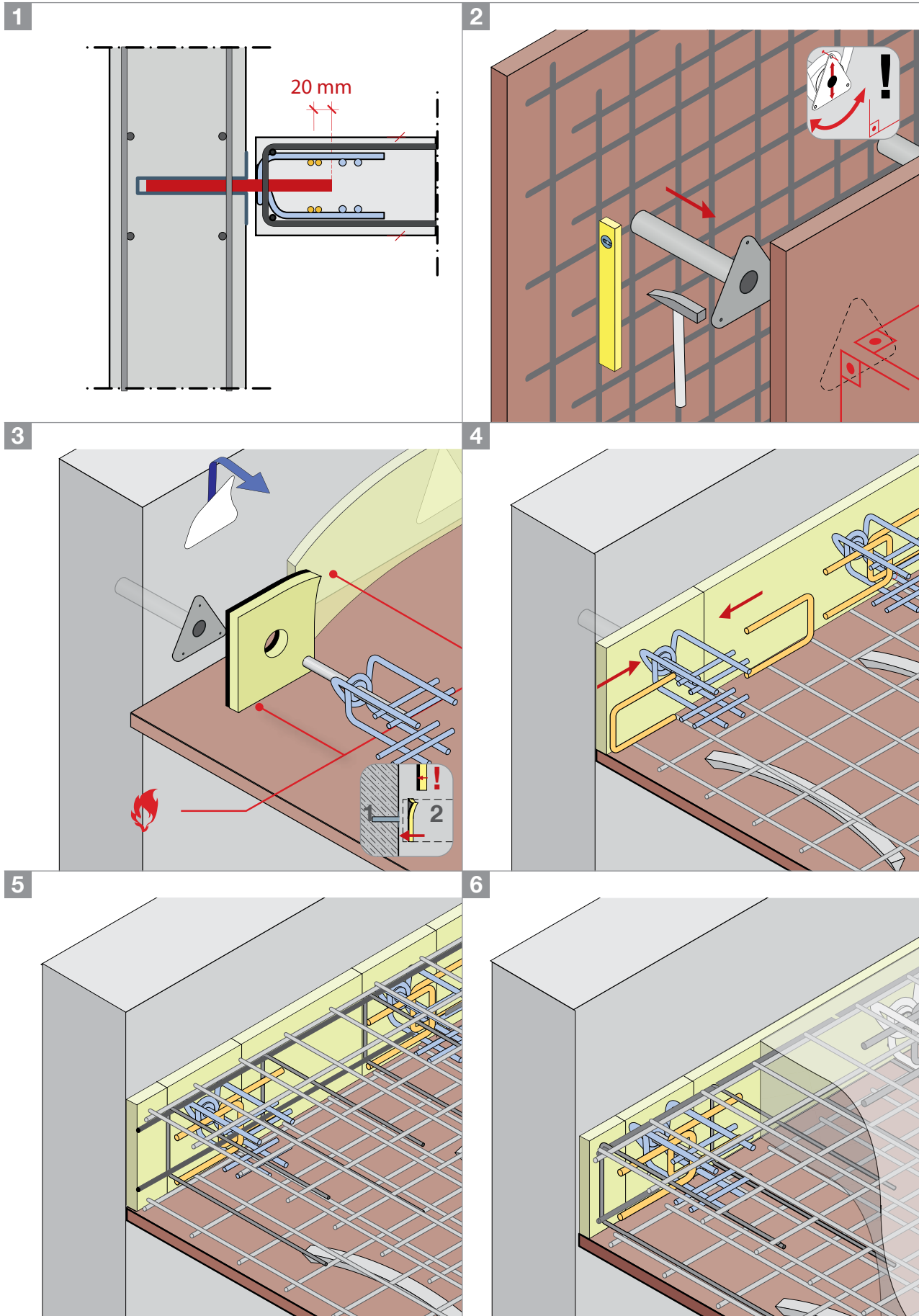

These application guidelines can only be regarded as a recommendation. They are no substitute for the specialised knowledge required for the installation. The instructions are always kept at the latest state of the art and are continually updated. Technical amendments are therefore expressly reserved - including without prior information to the customer. The most recent version can be found on our website at: www.maxfrank.com. Our general terms of sale are also applicable.

How to

Expansion joints with seal and shear force transmission

The construction of expansion joints in concrete elements is often very time-consuming in the planning and execution, especially when waterstops and components for the transmission of shear forces also have to be installed in the joints.

Planning and execution errors are avoided and faster building progress ensured through the use of prefabricated expansion joint rubber water bars, in which the shear force dowels and a receptacle cage for rubber water bars for expansion joints are already integrated.

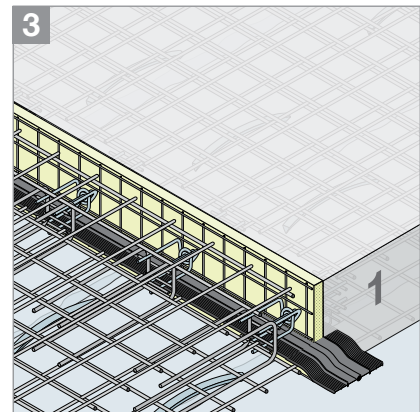
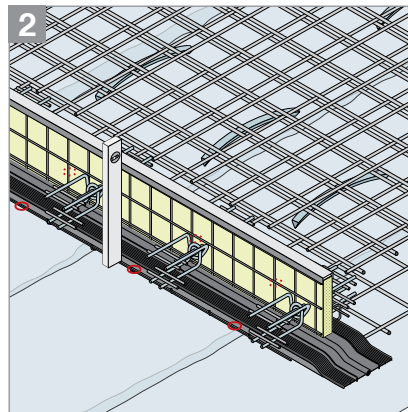
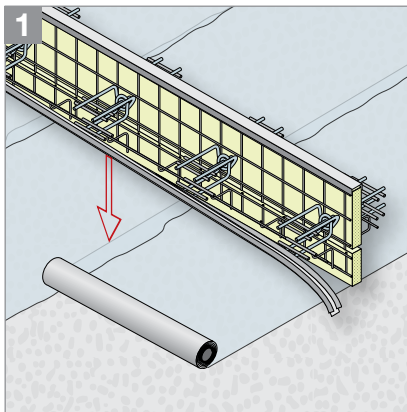

How to:

- The **Stremaform® formwork elements for expansion joints** are adapted precisely to the foundation planning. All standard and custom elements – such as transitions from the floor slab to the rising wall – are designed and produced in the works and delivered to the building site ready to install. Each element is allocated to its exact position in the formwork plan beforehand so that the detailed planning doesn't collide with the execution on site.
- The **Egcodorn® shear force dowels**, with which maximum shear forces can be transmitted even with minimum component thicknesses, are already integrated ex works. This significantly shortens the assembly time on the building site.
- The **expansion joint rubber water bar** is inserted on site so that it can be installed with the least number of joints possible.



BUILDING
COMMON GROUND

Egcodubel

Shear force dowel for small
and medium loads



Egcodubel shear force dowel

for small to medium loads

The Egcodubel serves to transmit shear forces in joints. The use of dowels is usually limited to statically subordinate applications (e.g. floor slabs).

Egcodubel dowels with sleeves are used for expansion joints and with small to medium loads or for structural component connection. Egcodubel dowels are available without sleeves for dowelling working and dummy joints. The Egcodubel dowels are chosen in a stainless steel or galvanised version depending on the area of use.

★ Advantages

- Extensive product range
- Inexpensive connection
- Fire protection R120 with fire protection collar
- Fully plastic-coated Egcodubel with CE marking

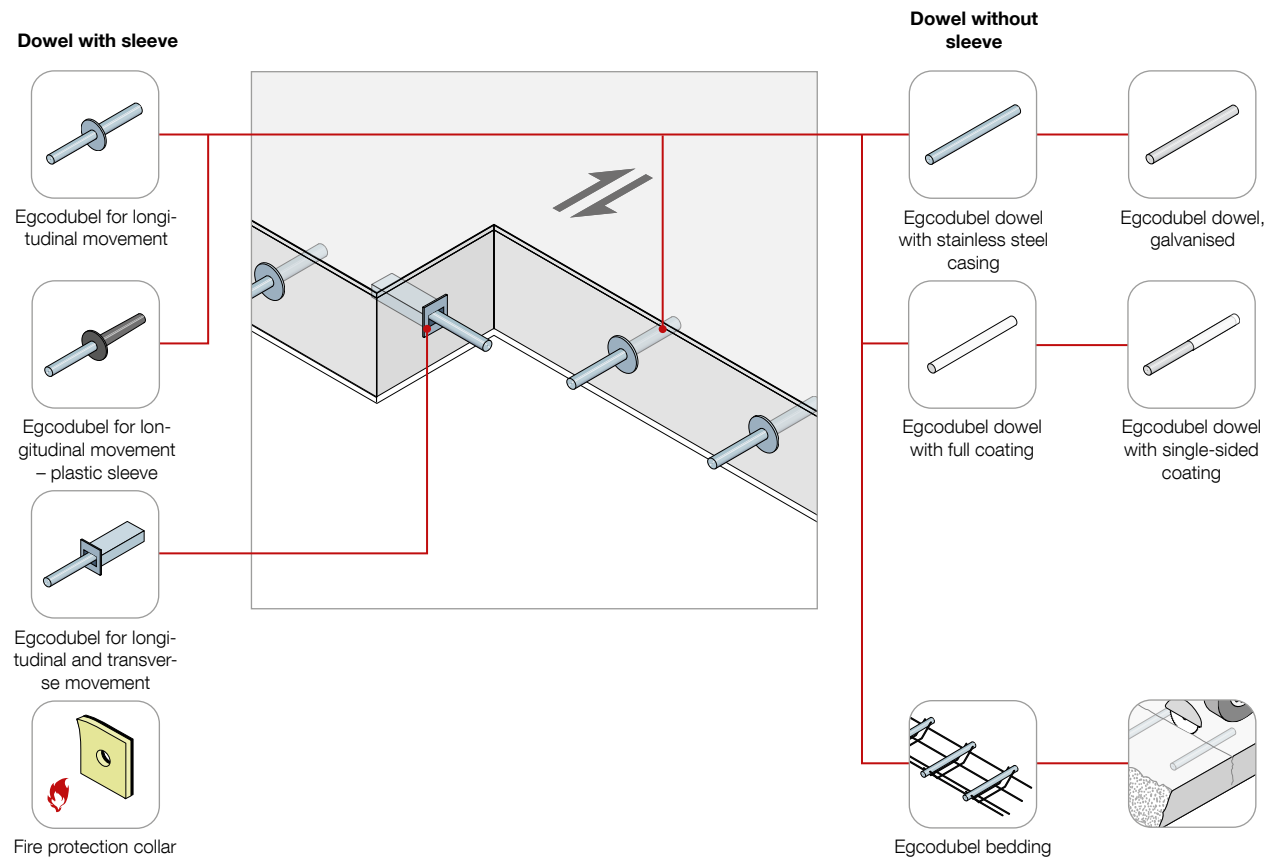

Type overview

Egcodubel with stainless steel sleeve

Egcodubel dowels with stainless steel jacket in conjunction with stainless steel sleeves offer excellent corrosion protection (corrosion resistance class III) and can also be used in corrosive environments. Depending on the desired load resistance, the dowel core can be selected in the standard quality S355 or in high-strength HF material. Either a longitudinal or, a longitudinal and transverse movable sleeve is chosen, depending on the direction of movement.

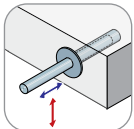

Egcodubel for longitudinal movement, stainless steel sleeve

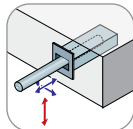

Egcodubel for longitudinal and transverse movement, stainless steel sleeve



Egcodubel with plastic sleeve

With simple load-bearing or structural connections of components, the Egcodubel can be used together with a longitudinally movable plastic sleeve. The variants S355 and HF are available as core material. Depending on the desired corrosion protection, Egcodubel dowels with stainless steel jacket or in a hot-dip galvanised version are used.

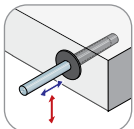

Egcodubel for longitudinal movement, plastic sleeve



Type designation

Example: **Egcodubel** **EDM** **27** **HF** **HQI**
 Egcodubel Type Diameter Dowel core Sleeve version¹⁾

Dowel type		Diameter [mm]	Dowel core/ dowel material	Sleeve version	
Stainless steel casing 	EDM	20	HF	Stainless steel sleeve for longitudinal movement 	HI
		22			
		25 ³⁾			
		27⁴⁾			
		30			
Galvanised ²⁾ 	EDV	20	S355	Stainless steel sleeve for longitudinal and transverse movement 	HQI
		22			
		25 ³⁾			
		27 ⁴⁾			
		30			
				Plastic sleeve for longitudinal movement up to max. Ø 30 mm 	H

- 1) Optional, omitted if using the dowel without sleeve
- 2) Can only be combined with plastic sleeve.
- 3) Only in galvanised version
- 4) Only in stainless steel version

Egcodubel without sleeve

Egcodubel dowels are also available without sleeves for dowelling working or dummy joints. If the corrosion protection is secured by the concrete cover, the galvanised variant of the Egcodubel is adequate for working or dummy joints. The variant with stainless steel jacket is used if higher corrosion protection is desired. The variants S235, S355 and HF are available as core material.

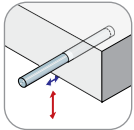

Egcodubel stainless steel/
galvanised



Egcodubel with coating

Egcodubel dowels with a soft plastic coating over half or the entire length are suitable for dummy joints without the necessity for an additional sleeve. They allow longitudinal displacements and prevent restraint stresses in the dowel direction. The dowels are made from S235. The surface of the half-length coated Egcodubel is hot-dip galvanised, it has an expansion sleeve.

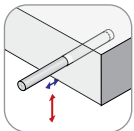

Egcodubel galvanised and coated



Type designation

Example: **Egcodubel** **EDV** **25** **S235** **E**
 Egcodubel Type Diameter Dowel core Expansion sleeve⁵⁾

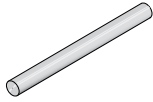
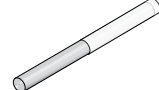
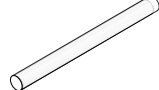
Dowel type		Diameter [mm]	Dowel core/ dowel material	Coating ⁶⁾	
	EDV	25	S235	half-length coating, expansion sleeve 	E
				full plastic coating 	B

⁵⁾ Optional, dowel without expansion sleeve or coating

⁶⁾ No sleeve is required in case of coating. Available only for dowel S235 with Ø 25 mm

Accessories

Fire protection collar

If there are fire protection requirements to be met, the Egcodubel® shear force dowels can be protected with the optionally available fire protection collar; the classification is then R120. The suitable fire protection collar is selected in relation to the dowel type and joint width, as standard 20 to 60 mm. The air gap between fire protection collar and concrete surface must be no wider than 10 mm.



Dowel holder

For the fast and secure mounting of Egcodubel dowels in slabs with dummy joints, we manufacture a dowel holder according to your specifications. Both the spacing of the dowels with respect to each other and the height position in the slab are secured and are easy to check.

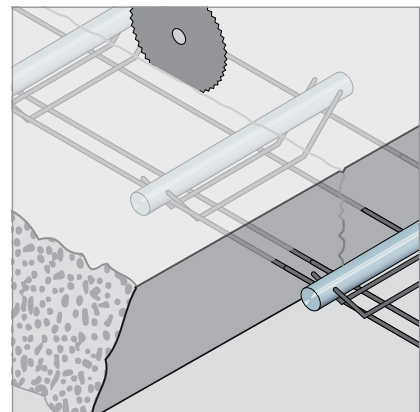
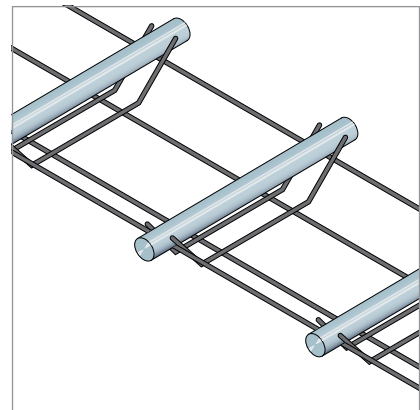

Design

Standard dowel

Types, application area

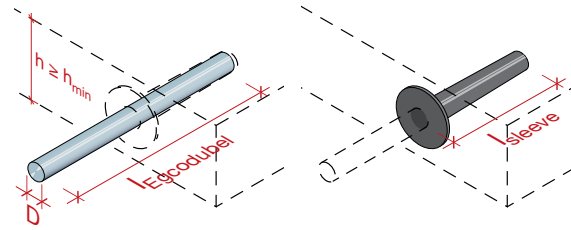

Standard dowel Nominal diameter, dowel D ¹⁾	Stainless steel EDM ...					Galvanised EDV ...			
	20	22	27	30	37	20	22	25	30
	Egcodubel Standard – S355								
Length Egcodubel l_D	315	340	405	445	–	320	350	385	450
Length sleeve, longitudinally movable l_H	200	210	240	260	–	200	210	230	260
Length sleeve, transversely movable l_H	200	215	245	265	–	–	–	–	–
	Egcodubel, high-strength – HF								
Length Egcodubel l_D	315	340	405	445	535	320	350	385	450
Length sleeve, longitudinally movable l_H	200	210	240	260	305	200	210	230	260
Length sleeve, transversely movable l_H	200	215	245	265	310	–	–	–	–
Minimum slab thickness h_{min}	160	180	200	220	260	160	180	200	220

¹⁾ Core diameter of stainless steel dowel = nominal diameter – 2 mm
Custom Egcodubel dowels on enquiry.

Egcodubel product load-bearing capacity

Provided concrete failure of the connected components can be ruled out, the system load-bearing capacity of the dowel connection is given by the product load-bearing capacity of the respective Egcodubel. The maximum occurring joint width is taken as the basis for the product load-bearing capacity in the individual case.

$V_{Rd,s}$ [kN] longitudinal displacement

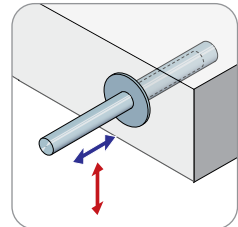

Standard dowel Nominal diameter of dowel D [mm]	Stainless steel EDM ...					Galvanised EDV ...			
	20	22	27	30	37	20	22	25	30
	Egcodubel Standard – S355								
Joint width [mm]									
10	18.8	24.2	40.9	53.1	–	25.8	32.2	43.1	64.8
20	14.1	18.4	32.2	42.5	–	19.4	24.5	33.6	52.3
30	11.3	14.9	26.5	35.4	–	15.5	19.8	27.5	43.6
40	9.4	12.5	22.6	30.4	–	12.9	16.6	23.3	37.3
50	8.1	10.8	19.6	26.6	–	11.1	14.3	20.2	32.7
60	7.1	9.4	17.4	23.6	–	9.7	12.6	17.8	29.0
	Egcodubel, high-strength – HF								
10	39.8	51.1	86.4	112.2	185.2	54.5	68.1	91.1	136.9
20	29.8	39.0	68.0	89.8	153.9	40.9	51.9	71.0	110.5
30	23.9	31.5	56.1	74.8	130.9	32.7	41.9	58.1	92.0
40	19.9	26.4	47.7	64.1	113.9	27.3	35.1	49.2	78.9
50	17.0	22.7	41.5	56.1	100.8	23.4	30.3	42.6	69.0
60	14.9	20.0	36.7	49.9	90.4	20.5	26.6	37.6	61.4

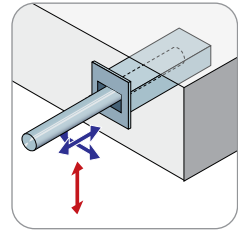
$V_{Rd,s}$ [kN] longitudinal and transverse displacement

Standard dowel Nominal diameter, dowel D [mm]	Stainless steel EDM ...				Galvanised EDV ...				
	20	22	27	30	37	20	22	25	30
Joint width [mm]	Egcodubel Standard – S355								
10	16.9	21.8	36.8	47.8	–	–	–	–	–
20	12.7	16.6	29.0	38.3	–	–	–	–	–
30	10.2	13.4	23.9	31.9	–	–	–	–	–
40	8.5	11.2	20.3	27.3	–	–	–	–	–
50	7.3	9.7	17.7	23.9	–	–	–	–	–
60	6.4	8.5	15.6	21.3	–	–	–	–	–
	Egcodubel, high-strength – HF								
10	35.8	46.0	77.7	100.9	166.7	–	–	–	–
20	26.8	35.1	61.2	80.8	138.5	–	–	–	–
30	21.5	28.3	50.5	67.4	117.8	–	–	–	–
40	17.9	23.8	42.9	57.7	102.5	–	–	–	–
50	15.3	20.5	37.4	50.5	90.7	–	–	–	–
60	13.4	18.0	33.1	44.9	81.4	–	–	–	–

Concrete load-bearing capacity of the dowel connection for slabs according to Eurocode 2

According to the respective boundary conditions, the following load-bearing capacities result for reinforced concrete slabs in the area of the dowel connection as pure concrete load-bearing capacities for selected degrees of reinforcement according to Eurocode 2. The following tables show which dowels can be used for the individual slab thicknesses. To determine the system load-bearing capacity of the dowel connection, an individual check must be made according to the selected Egcodubel as to whether the table value is decisive for the concrete load-bearing capacity or the respective product load-bearing capacity.

The concrete load-bearing capacities are based on the assumption that the forces can propagate without mutual influencing of the adjacent dowels; the minimum spacings specified apply. These spacings may be made smaller; however, different load-bearing capacities will then result.

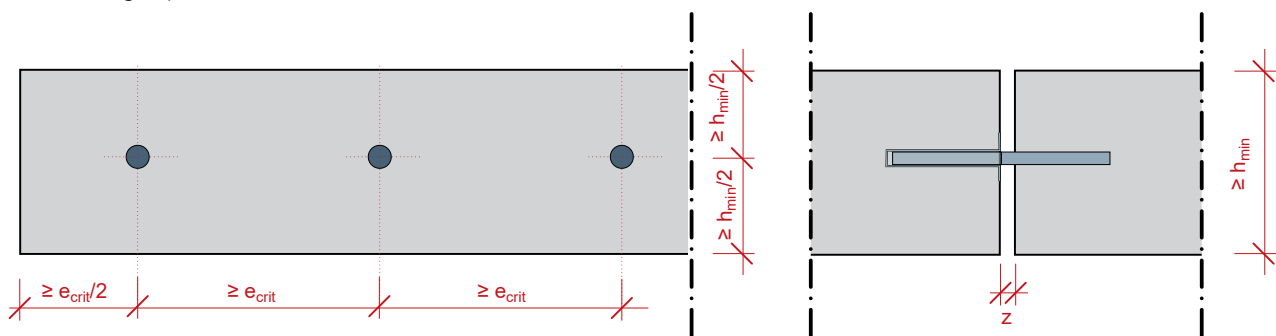

Pos. 1 or edge reinforcement in accordance with EC2 6.4.2 (5) + 9.3.1.4

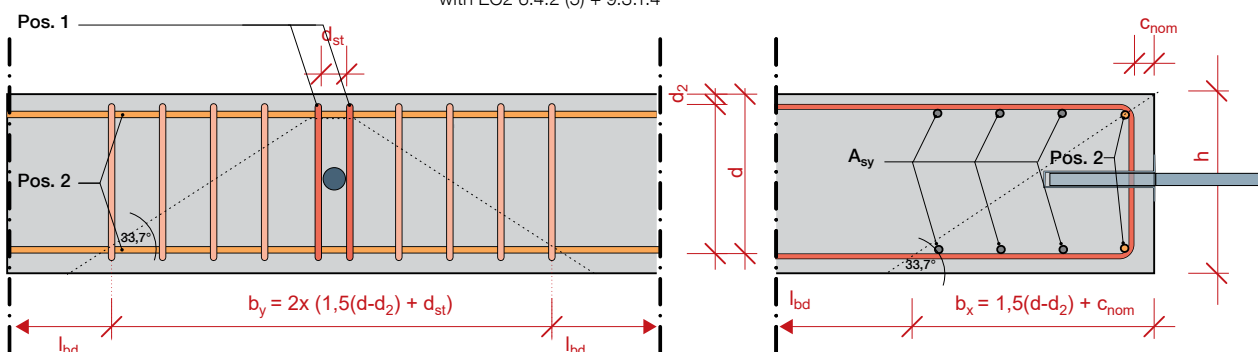

Concrete load-bearing capacity, longitudinal displacement

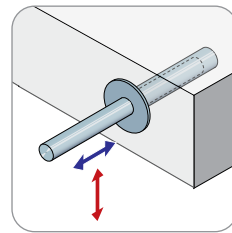

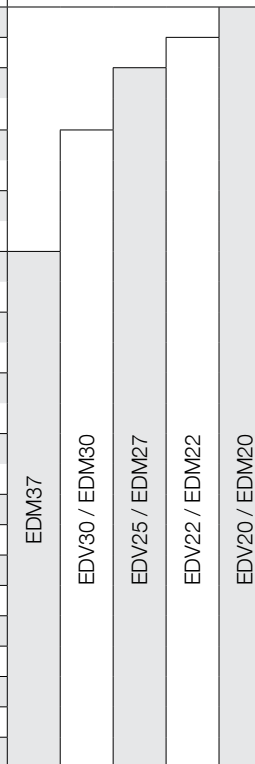
Slab thickness [mm]	$V_{Rd,C}$ [kN] per dowel, longitudinal displacement			Item 1	Pos. 2 ¹⁾	e_{crit} ²⁾	usable dowel in relation to minimum slab thickness
	C20/25	C25/30	C30/37				
160	14.8	16.6	18.1	2Ø10	Ø10	310	
180	16.3	18.3	20.2	2Ø10	Ø10	370	
200	17.2	19.4	21.3	2Ø10	Ø10	440	
	23.1	25.9	28.5	2Ø12	Ø12	440	
220	18.8	21.1	23.3	2Ø10	Ø10	500	
	24.9	28.1	30.9	2Ø12	Ø12	500	
240	26.8	30.2	33.3	2Ø12	Ø12	560	
	34.1	38.4	42.3	2Ø14	Ø14	560	
260	27.9	31.4	34.7	2Ø12	Ø12	630	
	35.4	39.8	43.9	2Ø14	Ø14	630	
280	29.7	33.5	37.1	2Ø12	Ø12	690	
	37.5	42.3	46.7	2Ø14	Ø14	690	
300	39.6	44.8	49.5	2Ø14	Ø14	750	
	48.6	54.8	60.5	2Ø16	Ø16	750	
350	44.9	50.9	56.4	2Ø14	Ø14	900	
	54.6	61.8	68.4	2Ø16	Ø16	900	
400	60.6	68.7	76.2	2Ø16	Ø16	1050	
450	66.6	75.7	84.0	2Ø16	Ø16	1200	
500	72.5	82.5	91.8	2Ø16	Ø16	1350	
550	78.5	89.4	99.5	2Ø16	Ø16	1500	
600	84.4	96.2	107.3	2Ø16	Ø16	1650	
650	90.2	103.1	115.0	2Ø16	Ø16	1800	
700	96.1	109.9	122.7	2Ø16	Ø16	1950	
750	102.0	116.7	130.4	2Ø16	Ø16	2100	
800	107.9	123.5	138.1	2Ø16	Ø16	2250	

1) The stated reinforcement must be inserted at top and bottom respectively.

2) The minimum lateral edge distance is $e_{crit}/2$.

Concrete cover $c_{nom} = 35$ mm

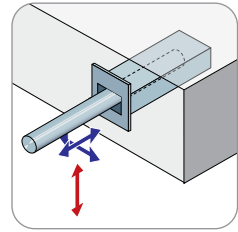
Concrete load-bearing capacity, longitudinal and transverse displacement

Slab thickness [mm]	$V_{Rd,C}$ [kN] per dowel, longitudinal and transverse displacement			Item 1	Pos. 2 ¹⁾	e_{crit} ²⁾	usable dowel in relation to minimum slab thickness
	Concrete C20/25	Concrete C25/30	Concrete C30/37				
160	12.5	14.0	15.4	2Ø10	Ø10	340	
180	13.0	14.5	15.9	2Ø10	Ø10	400	
200	13.8	15.5	17.0	2Ø10	Ø10	470	
	18.7	20.9	22.9	2Ø12	Ø12	470	
220	15.2	17.1	18.9	2Ø10	Ø10	530	
	20.4	22.9	25.1	2Ø12	Ø12	530	
240	22.1	24.8	27.3	2Ø12	Ø12	590	
	28.3	31.7	34.9	2Ø14	Ø14	590	
260	23.1	26.0	28.7	2Ø12	Ø12	660	
	29.4	33.1	36.4	2Ø14	Ø14	660	
280	24.8	27.9	30.9	2Ø12	Ø12	720	
	31.4	35.4	39.0	2Ø14	Ø14	720	
300	33.3	37.6	41.5	2Ø14	Ø14	780	
	41.0	46.2	50.9	2Ø16	Ø16	780	
350	38.2	43.2	47.8	2Ø14	Ø14	930	
	46.5	52.6	58.1	2Ø16	Ø16	930	
400	52.0	58.9	65.3	2Ø16	Ø16	1080	
450	57.4	65.2	72.4	2Ø16	Ø16	1230	
500	62.8	71.4	79.4	2Ø16	Ø16	1380	
550	68.2	77.6	86.4	2Ø16	Ø16	1530	
600	73.5	83.8	93.4	2Ø16	Ø16	1680	
650	78.9	90.0	100.4	2Ø16	Ø16	1830	
700	84.2	96.2	107.4	2Ø16	Ø16	1980	
750	89.5	102.3	114.3	2Ø16	Ø16	2130	
800	94.8	108.5	121.3	2Ø16	Ø16	2280	

1) The stated reinforcement must be inserted at top and bottom respectively.

2) The minimum lateral edge distance is $e_{crit}/2$.

Concrete cover $c_{nom} = 35$ mm

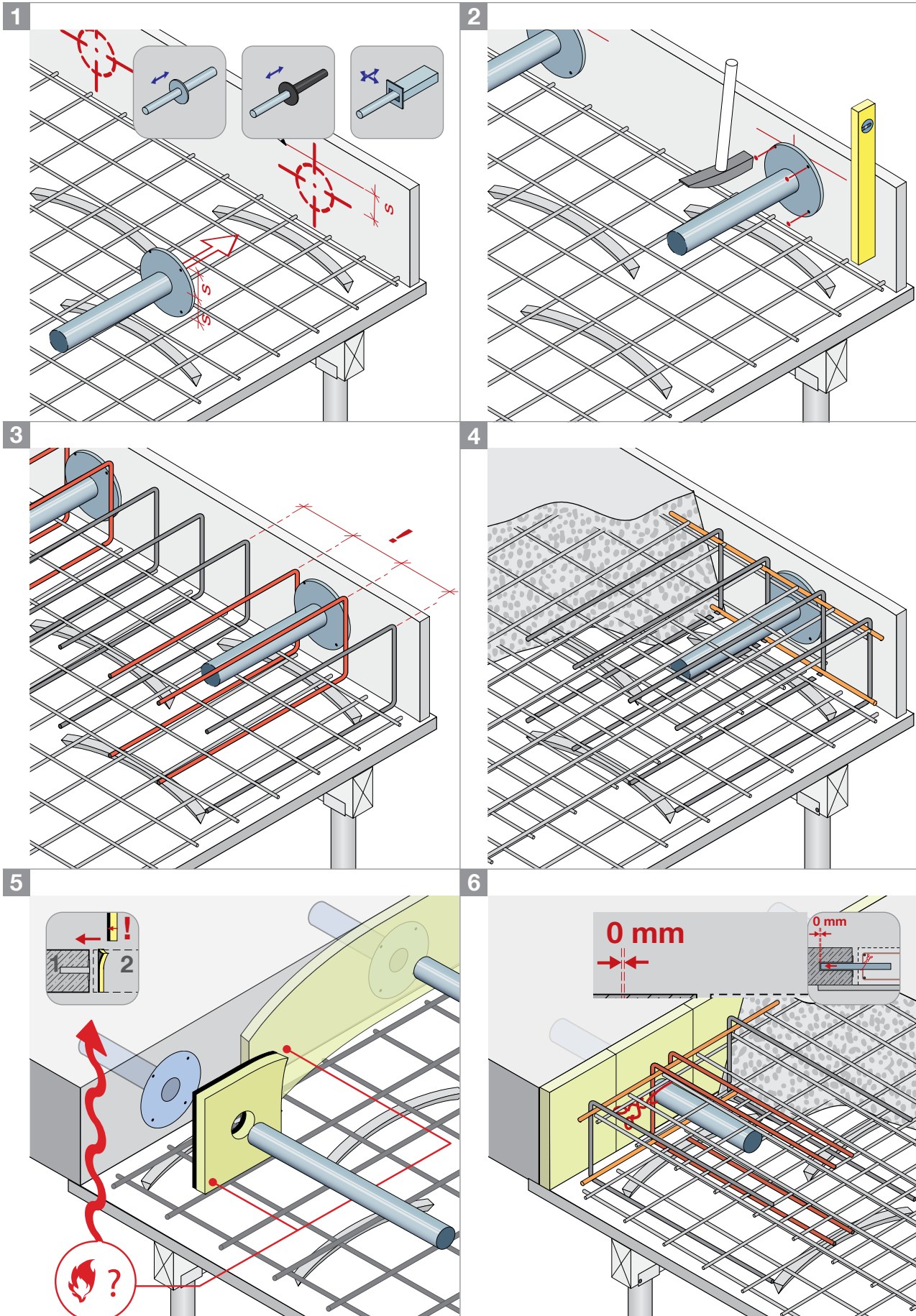

These application guidelines can only be regarded as a recommendation. They are no substitute for the specialised knowledge required for the installation. The instructions are always kept at the latest state of the art and are continually updated. Technical amendments are therefore expressly reserved - including without prior information to the customer. The most recent version can be found on our website at: www.maxfrank.com. Our general terms of sale are also applicable.



BUILDING
COMMON GROUND

Egcodorn®

Shear force dowel DND for
dynamic stress



Egcodorn® DND shear force dowel

for dynamic stress

The design of the Egcodorn® DND in stainless steel is optimised for dynamically stressed joints and is the only shear force dowel with a German National Approval for this application case. The Egcodorn® is used wherever frequently recurring loads act, e.g. in mass-spring systems, crane runways or in multi-storey car parks.

★ Advantages

- Absorption of primarily non-static loads
- Allows longitudinal displacement
- Made of stainless steel for maximum corrosion protection
- Time and cost advantages thanks to combination with Stremaform® formwork element

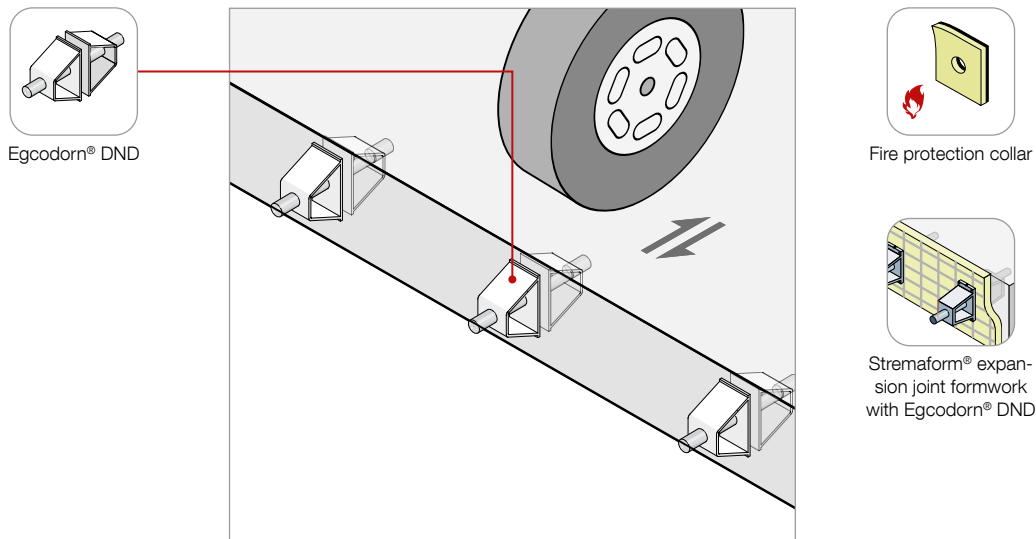

More information can be found in our Egcodorn® DND brochure.



BUILDING
COMMON GROUND

Egcopal

Impact sound insulated shear
force dowel



Egcopal impact sound insulated shear force dowel

Bedding of stair landings and arcades

The requirements for sound insulation in buildings have been increasing for years. To meet the requirements, impact sound insulation of stairs and stair landings must be certified. The impact noise insulated Egcopal shear force connector reduces impact sound by decoupling components. It is used for the bedding of stair landings, arcades and cantilever balconies and transmits the shear forces acting in the connection joint. At the same time, the acoustically decoupled bedding ensures that the transmission of irritating noises into adjacent rooms is insulated – this increases the comfort and well-being of the residents.

★ Advantages

- German National Approval for Egcopal SP, Egcopal SPH, Egcopal SPX
- Impact sound properties tested in an accredited test laboratory according to DIN 7396
- Impact sound level difference of stair landing $\Delta L^*_{w, \text{stair landing}}$ up to 35 dB
- Fire protection rating F120
- Stainless steel version
- No restrictions of the exposure class acc. to EC2

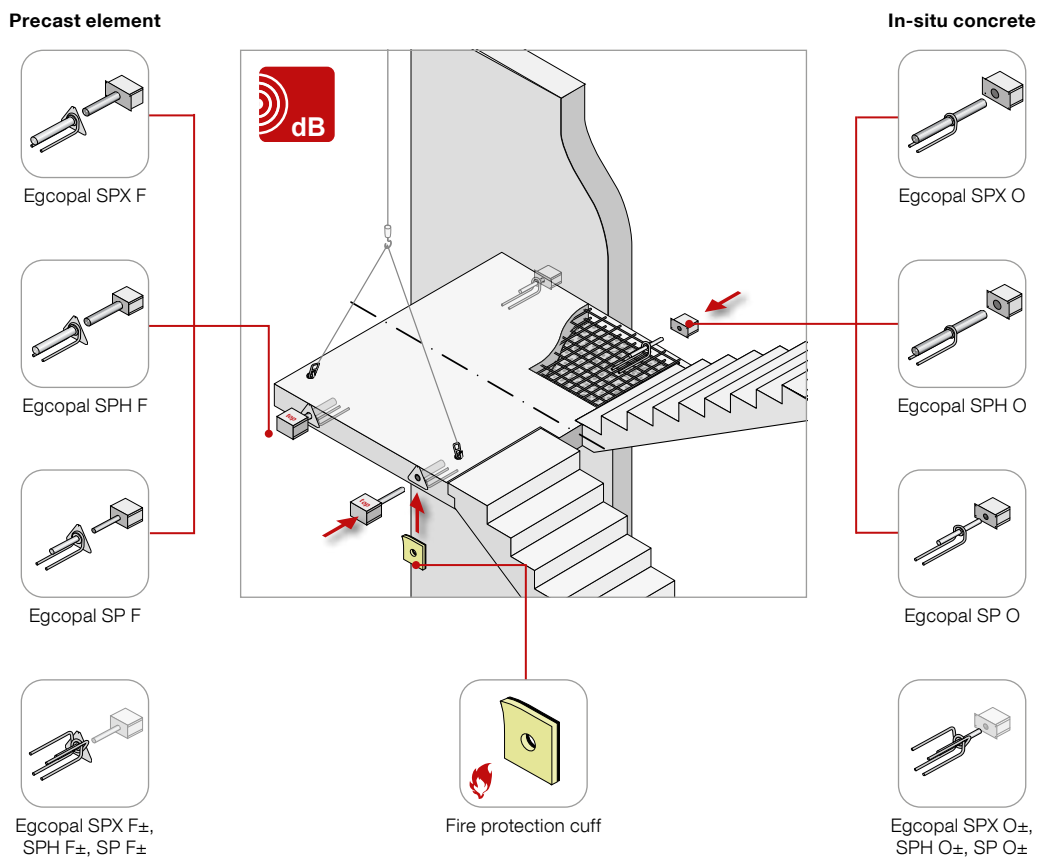

More information can be found in our **Building Acoustics brochure**.



BUILDING
COMMON GROUND

Egcodorn Software 2.0

The new generation for the
design of shear force dowels

m 2.00.19254

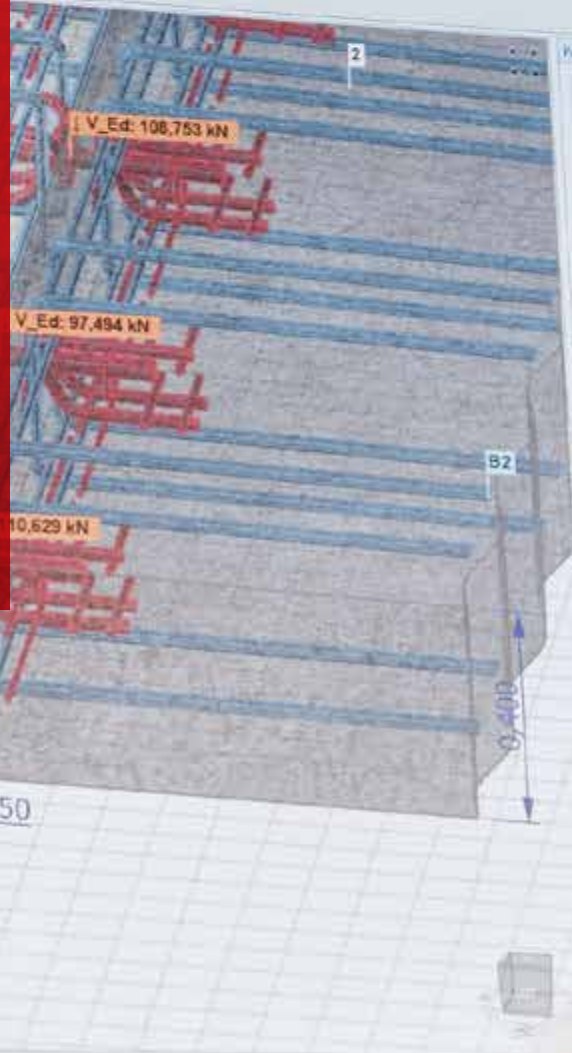

The Egcodorn software is free for you!

Let the high performance of the software
convince you and simplify your planning!



Egcodorn Software 2.0

The further developed and redesigned Egcodorn software simplifies the design and dimensioning of all MAX FRANK shear force dowel types.

Which MAX FRANK products can you design with the software?

- **Egcodorn® WN/WQ shear force dowel**
for high loads in expansion joints
- **Egcodorn® DND shear force dowel**
for joints subjected to dynamic loads
- **Egcodubel shear force dowel**
for small and medium loads in expansion joints
- **Egcopal impact sound insulated shear force dowels**
for stair landing, arcade and stair flight decoupling

What functions does the free Egcodorn software offer you?

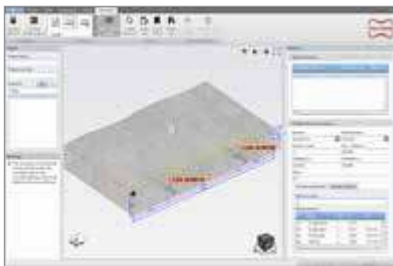

- Intuitively usable thanks to clearly structured user interfaces
- Freely rotatable 3D view makes operation and orientation easier



- All typical connection situations selectable as templates
- All available shear force dowels selectable – even impact noise insulated types

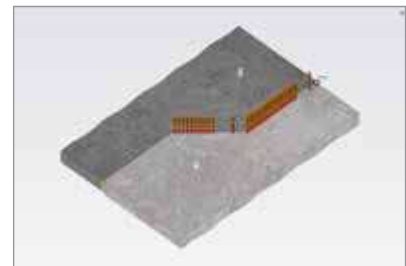

- Virtually unlimited possibilities for joint layouts

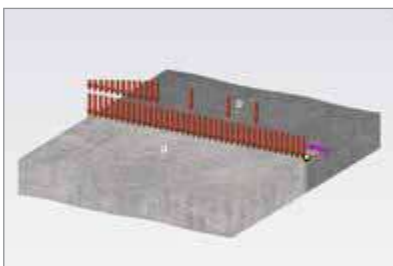

- Forces as in reality – even horizontal forces are possible

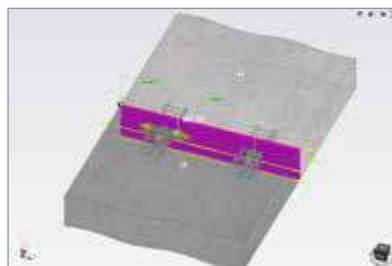

- Economy: all available solution variants are suggested, sorted according to cost criteria
- Dowel position: suggested dowel positions can be moved "by hand"

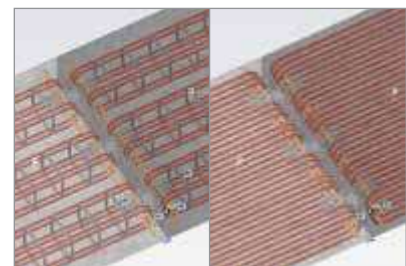

- Choose from: Longitudinal reinforcement or shear reinforcement
- Use the unique advantage for designing with shear reinforcement.



Free download of the Egcodorn software:
www.maxfrank.com/egcodorn-software



MAX FRANK Group

Headquarters:

Max Frank GmbH & Co. KG

Mitterweg 1

94339 Leiblfing

Germany

www.maxfrank.com

