

# FORTEC

The Ultimate Splicing System

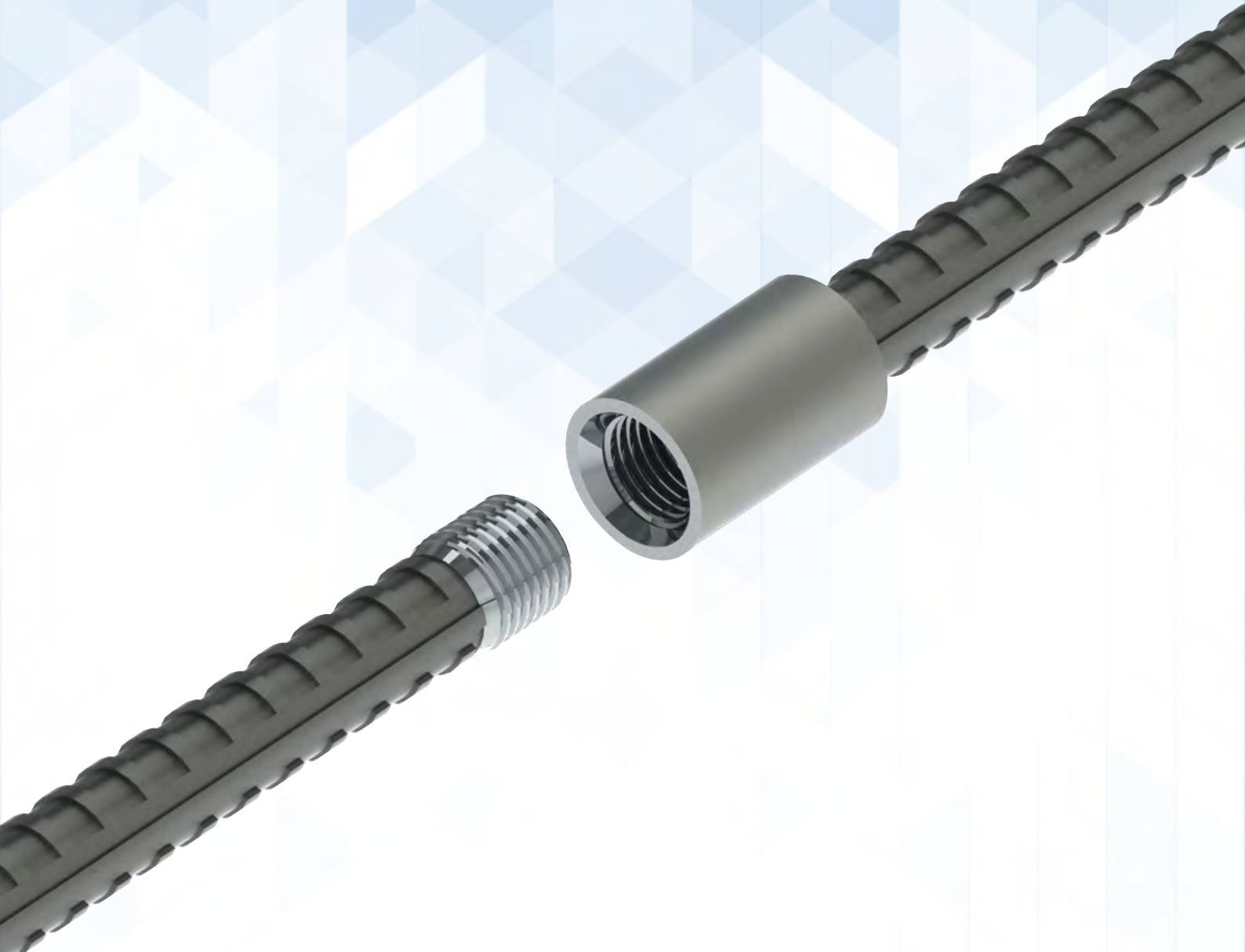

**Dextra**

## Product features

Fortec® is a parallel threaded mechanical splicing system designed for the connection of concrete reinforcing bars from Ø12 to 50 mm (ASTM #4 to #18).

Fortec® couplers are designed and manufactured in compliance with Eurocode 2, BS 8110, DIN 1045, ACI 318, IBC, AASHTO, ASME Sec III Div 2.

## Benefits

- One standard coupler for all splicing requirements (Standard / Position).
- Easy installation, no torque wrench required.
- No reduction of the bar cross section area.
- Allows full ductile elongation of bars.
- Type 2 coupler suitable for seismic areas.
- Tested under reverse cyclic conditions.
- Solves bar congestion problems.

## Site equipment



The 3 machines necessary to Fortec® system rebar preparation are engineered by Dextra.

## Rebar preparation: A 3-step process

### STEP 01 Cutting

The end of the reinforcing bar is sawn square.



### STEP 02 Cold forging

The sawn end of the reinforcing bar is then enlarged by a patented cold forging process. The core diameter of the bar is increased to a pre-determined size.



### STEP 03 Threading

Finally, the enlarged end of the rebar is threaded to the required length.

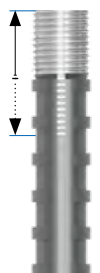

## Splicing methods

### Standard splice (Type A)

Easy connection by bar rotation until full thread engagement.

Thanks to the parallel thread:

- No risk of thread mis-match.
- No risk of cross-threading.



### Position splice (Type B)

Even when both bars cannot be turned, the Fortec® system uses a standard coupler.

The coupler is fully engaged onto the extended thread of the connecting bar (step 1).

The assembly is simply completed by bringing the bars end to end and screwing back the coupler onto the first bar until full engagement (step 2).



### Position splice (Type C)

The Position splice Type C is different from Type B in that it has an additional lock nut to maintain the continuation bar in a determined position.

# Applications

## Bridging splice

To connect bars that can't be brought butt to butt, Fortec® Bridging Splice is your solution. This is often the case with complex prefabricated cages.

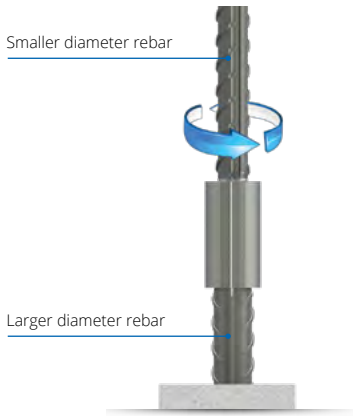
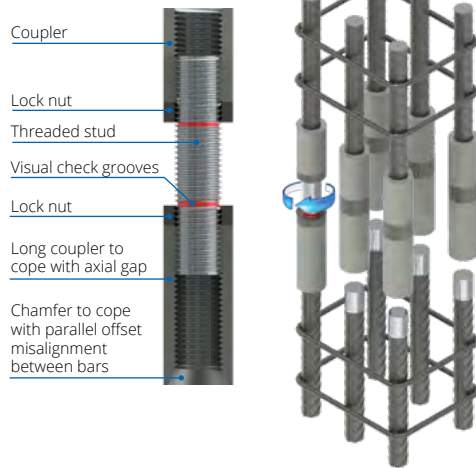

## Transition splice

When bars of different sizes need to be spliced, it is not always possible to reduce the size of the larger bar end and use a standard coupler.

For such cases, the Fortec® system offers specific transition couplers that conveniently avoid the difficult task of planning in advance the need of transitions.

## Headed Bars

Also called "End Anchors", they are a convenient alternative to hooked bars to provide end anchorages in congested areas. Fortec® standard anchorage heads are circular and have a net bearing area of 4 times or 9 times the cross-section of the bar.

The large headed bar is an ETA-assessed and CE-marked solution.



## Weldable couplers

For composite construction where concrete reinforcement bars must be welded to structural steel, use Fortec® weldable couplers, which are specially made from low carbon steel and which have a large chamfer for bevel welding.

## Generic specification

- › No reduction of the nominal cross section area of the parent bars.
- › No reduction of the ductility of the reinforcing bar.
- › Couplers are individually marked to allow full traceability of the material.
- › Parallel-thread system.

**Note :** The information in this catalogue is considered up to date at the time of publication. We reserve the right to make technical and design changes at any time. Dextra shall not accept liability for the accuracy of the information in this publication or for any printing errors.



## Quality Assurance



## Approvals & Certifications



## Environmental Verifications



## Design Tools

Available on [www.dextragroup.com](http://www.dextragroup.com)





Burj Khalifa Tower, Dubai, UAE



Nhat Tan Bridge, Vietnam

Commercial presence  
in more than **55 countries**



**HEADQUARTERS THAILAND**

Dextra Holding Services Co., Ltd.  
Dextra Manufacturing Co., Ltd.  
Tel: (66) 2119 4400, (66) 2 021 3800  
E-mail: thailand@dextragroup.com



**EUROPE**

Dextra Europe SARL.  
Tel: (33) 1 45 53 70 82  
E-mail: europe@dextragroup.com



**NORTH AMERICA**

Dextra America Inc.  
Tel: (1) 909 966 4843  
E-mail: america@dextragroup.com



**CHINA**

Dextra Building Products (Guangdong) Co., Ltd.  
Tel: (86) 20 2261 9901  
E-mail: china@dextragroup.com



**MIDDLE EAST**

Dextra Middle-East FZE  
Tel: (971) 4886 5620  
E-mail: middleeast@dextragroup.com



**LATIN AMERICA**

Dextra Latam  
Tel: (507) 6454 8100  
E-mail: latam@dextragroup.com



**HONG KONG**

Dextra Pacific Ltd. & Dextra China Ltd.  
Dextra Pacific Plumbing Ltd.  
Tel: (852) 2820 5201  
E-mail: dplbuilding@dextragroup.com



**INDIA**

Dextra India Pvt. Ltd.  
Tel: (91) 22 4503 5611  
E-mail: india@dextragroup.com

**Contact Us**



reliable  
connections



www.dextragroup.com